

AIR CONDITIONING SYSTEMS

# CITY MULTI



## DATA BOOK

MODEL

**PUHY-M200-300YNW-A1(-BS)**

**PUHY-EM200-300YNW-A1(-BS)**



Line-up of Outdoor Units of R32 CITY MULTI

Heat Pump Y-Series



PUHY-M200YNW-A1(-BS)      PUHY-M250YNW-A1(-BS)  
PUHY-M300YNW-A1(-BS)

**8, 10, 12HP**

Heat Pump High efficiency Y-Series



PUHY-EM200YNW-A1(-BS)      PUHY-EM250YNW-A1(-BS)  
PUHY-EM300YNW-A1(-BS)

**8, 10, 12HP**

**PUHY-M-YNW-A1, PUHY-EM-YNW-A1**

1. SPECIFICATIONS .....	2
2. EXTERNAL DIMENSIONS .....	8
3. CENTER OF GRAVITY .....	12
4. ELECTRICAL WIRING DIAGRAMS .....	13
5. SOUND LEVELS .....	14
5-1. Sound levels in cooling mode .....	14
5-2. Sound levels in heating mode .....	16
6. VIBRATION LEVEL .....	18
7. OPERATION TEMPERATURE RANGE .....	19
8. CAPACITY TABLES .....	20
8-1. Selection of Cooling/Heating Units .....	20
8-2. Correction by temperature .....	26
8-3. Correction by total indoor .....	34
8-4. Correction by refrigerant piping length .....	36
8-5. Correction at frost and defrost .....	37
8-6. Correction at evaporation-temperature (ET) control .....	37
9. OPTIONAL PARTS .....	38
9-1. JOINT .....	38
9-2. HEADER .....	39
9-3. FIN GUARD .....	40
10. ELECTRICAL WORK .....	41
10-1. General cautions .....	41
10-2. Power supply for Outdoor unit .....	42
10-3. Power cable specifications .....	43
10-4. Power supply examples .....	44
11. M-NET CONTROL .....	45
11-1. Transmission cable length limitation .....	45
11-2. Transmission cable specifications .....	46
11-3. System configuration restrictions .....	47
11-4. Address setting .....	51
12. PIPING DESIGN .....	62
12-1. R32 Piping material .....	62
12-2. Piping Design .....	64
12-3. Refrigerant charging calculation .....	67
13. OUTDOOR INSTALLATION .....	69
13-1. Requirement on installation site .....	69
13-2. Spacing .....	70
13-3. Piping direction .....	72
13-4. Countermeasure to wind .....	75
13-5. Precautions for installing a panel heater .....	75
13-6. Caution on selecting outdoor units .....	75

# 1. SPECIFICATIONS

Y-Series

PUHY-M-YNW-A1, EM-YNW-A1

Model		<b>PUHY-M200YNW-A1 (-BS)</b>		
Power source		3-phase 4-wire 380-400-415 V 50/60 Hz		
Cooling capacity (Nominal)	*1	kW	22.4	
		kcal/h	20,000	
		BTU/h	76,400	
	Power input	kW	4.72	
	Current input	A	7.9-7.5-7.2	
	EER	kW/kW	4.74	
	SEER	kW/kW	-	
Temp. range of cooling	Indoor	W.B.	15.0~24.0°C (59~75°F)	
	Outdoor	D.B.	-5.0~52.0°C (23~126°F)	
Heating capacity (Max)	*2	kW	25.0	
		kcal/h	21,500	
		BTU/h	85,300	
	Power input	kW	5.08	
	Current input	A	8.5-8.1-7.8	
	COP	kW/kW	4.92	
	(Nominal)	*3	kW	22.4
			kcal/h	19,400
			BTU/h	76,400
		Power input	kW	4.33
Current input	A	7.3-6.9-6.6		
COP	kW/kW	5.17		
SCOP	kW/kW	-		
Temp. range of heating	Indoor	D.B.	15.0~27.0°C (59~81°F)	
	Outdoor	W.B.	-20.0~15.5°C (-4~60°F)	
Indoor unit connectable	Total capacity	50~130% of outdoor unit capacity		
	*8 Model/Quantity	M20~M140/1~13		
Sound pressure level (measured in anechoic room) *4, 5	dB <A>	58.0/59.0		
Sound power level (measured in anechoic room) *4	dB <A>	75.0/78.0		
Refrigerant piping diameter	Liquid pipe	mm (in.)	9.52 (3/8) Brazed	
	Gas pipe	mm (in.)	22.2 (7/8) Brazed	
FAN	Type x Quantity		Propeller fan x 1	
	Air flow rate	m <sup>3</sup> /min	170	
		L/s	2,833	
		cfm	6,003	
	Control, Driving mechanism		Inverter-control, Direct-driven by motor	
	Motor output	kW	0.92 x 1	
*6 External static press.	0 Pa (0 mmH <sub>2</sub> O)			
Compressor	Type	Inverter scroll hermetic compressor		
	Starting method	Inverter		
	Motor output	kW	3.5	
	Case heater	kW	-	
	Lubricant	MEL46EH		
External finish		Pre-coated galvanized steel sheets (+powder coating for -BS type) <MUNSELL 5Y 8/1 or similar>		
External dimension H x W x D		mm	1,858 (1,798 without legs) x 920 x 740	
		in.	73-3/16 (70-13/16 without legs) x 36-1/4 x 29-3/16	
Protection devices	High pressure protection		High pressure sensor, High pressure switch at 4.15 MPa (601 psi)	
	Inverter circuit (COMP./FAN)		Over-heat protection, Over-current protection	
	Compressor		-	
	Fan motor		-	
Refrigerant	Type x original charge		R32 x 6.5 kg (15 lbs)	
	Control		LEV and HIC circuit	
Net weight	kg (lbs)	222 (490)		
Heat exchanger		Salt-resistant cross fin & copper tube		
HIC circuit (HIC: Heat Inter-Changer)		Copper pipe, tube-in-tube structure		
Defrosting method		Auto-defrost mode (Reversed refrigerant cycle, Hot gas)		
Drawing	External	WKL94T604		
	Wiring	WKE94G770		
Standard attachment	Document	Installation Manual		
	Accessory	-		
Optional parts		Joint: CMY-Y102SS/LS-G2 Header: CMY-Y104/108/1010-G		
Remarks		Details on foundation work, duct work, insulation work, electrical wiring, power source switch, and other items shall be referred to the Installation Manual. Due to continuing improvement, above specifications may be subject to change without notice.		

Notes:	Unit converter
1. Nominal cooling conditions (subject to JIS B8615-2) Indoor: 27°C D.B./19°C W.B. (81°F D.B./66°F W.B.), Outdoor: 35°C D.B./24°C W.B. (95°F D.B./75°F W.B.) Pipe length: 7.5 m (24-9/16 ft.), Level difference: 0 m (0 ft.)	BTU/h =kW x 3,412
2. Nominal heating conditions (subject to JIS B8615-2) Indoor: 20°C D.B. (68°F D.B.), Outdoor: 7°C D.B./6°C W.B. (45°F D.B./43°F W.B.) Pipe length: 7.5 m (24-9/16 ft.), Level difference: 0 m (0 ft.)	cfm =m <sup>3</sup> /min x 35.31
3. Nominal heating conditions (subject to JIS B8615-2) Indoor: 20°C D.B. (68°F D.B.), Outdoor: 7°C D.B./6°C W.B. (45°F D.B./43°F W.B.) Pipe length: 7.5 m (24-9/16 ft.), Level difference: 0 m (0 ft.)	lbs =kg/0.4536
4. Cooling mode/Heating mode	
5. The sound pressure level measured by the conventional method in JIS for reference purpose.	
6. External static pressure option is available (30 Pa, 60 Pa, 80 Pa/3.1 mmH <sub>2</sub> O, 6.1 mmH <sub>2</sub> O, 8.2 mmH <sub>2</sub> O). Consult your dealer about the specification when setting External static pressure option.	
7. R32 is flammable, and certain restrictions apply to the installation of units. When installing new units, moving the existing units, or changing the layout of the room, ensure that installation restrictions are observed. For detail, refer to the section in the Databook on installation restrictions.	
8. When connecting the indoor units of M20 or M25, the maximum connectable number of indoor units is 8.	*Above specification data is subject to rounding variation.

# 1. SPECIFICATIONS

Y-Series

PUHY-M-YNW-A1, EM-YNW-A1

Model		PUHY-M250YNW-A1 (-BS)			
Power source		3-phase 4-wire 380-400-415 V 50/60 Hz			
Cooling capacity (Nominal)	*1	kW	28.0		
		kcal/h	25,000		
		BTU/h	95,500		
	Power input		kW	6.96	
	Current input		A	11.7-11.1-10.7	
	EER		kW/kW	4.02	
	SEER		kW/kW	-	
Temp. range of cooling	Indoor	W.B.	15.0~24.0°C (59~75°F)		
	Outdoor	D.B.	-5.0~52.0°C (23~126°F)		
Heating capacity (Max)	*2	kW	31.5		
		kcal/h	27,100		
		BTU/h	107,500		
	Power input		kW	7.14	
	Current input		A	12.0-11.4-11.0	
	COP		kW/kW	4.41	
	(Nominal)	*3	kW	28.0	
			kcal/h	25,000	
			BTU/h	95,500	
		Power input		kW	5.95
		Current input		A	10.0-9.5-9.1
		COP		kW/kW	4.70
		SCOP		kW/kW	-
Temp. range of heating	Indoor	D.B.	15.0~27.0°C (59~81°F)		
	Outdoor	W.B.	-20.0~15.5°C (-4~60°F)		
Indoor unit connectable	Total capacity	50~130% of outdoor unit capacity			
	*8 Model/Quantity	M20-M140/1~16			
Sound pressure level (measured in anechoic room) *4, 5		dB <A>	60.0/61.0		
Sound power level (measured in anechoic room) *4		dB <A>	78.0/80.0		
Refrigerant piping diameter	Liquid pipe	mm (in.)	9.52 (3/8) Brazed		
	Gas pipe	mm (in.)	22.2 (7/8) Brazed		
FAN	Type x Quantity		Propeller fan x 1		
	Air flow rate	m <sup>3</sup> /min	185		
		L/s	3,083		
		cfm	6,532		
	Control, Driving mechanism		Inverter-control, Direct-driven by motor		
	Motor output		kW	0.92 x 1	
*6 External static press.		0 Pa (0 mmH <sub>2</sub> O)			
Compressor	Type		Inverter scroll hermetic compressor		
	Starting method		Inverter		
	Motor output		kW	5.3	
	Case heater		kW	-	
	Lubricant		MEL46EH		
External finish		Pre-coated galvanized steel sheets (+powder coating for -BS type) <MUNSELL 5Y 8/1 or similar>			
External dimension H x W x D		mm	1,858 (1,798 without legs) x 920 x 740		
		in.	73-3/16 (70-13/16 without legs) x 36-1/4 x 29-3/16		
Protection devices	High pressure protection		High pressure sensor, High pressure switch at 4.15 MPa (601 psi)		
	Inverter circuit (COMP./FAN)		Over-heat protection, Over-current protection		
	Compressor		-		
	Fan motor		-		
Refrigerant	Type x original charge		R32 x 6.5 kg (15 lbs)		
	Control		LEV and HIC circuit		
Net weight		kg (lbs)	222 (490)		
Heat exchanger		Salt-resistant cross fin & copper tube			
HIC circuit (HIC: Heat Inter-Changer)		Copper pipe, tube-in-tube structure			
Defrosting method		Auto-defrost mode (Reversed refrigerant cycle, Hot gas)			
Drawing	External		WKL94T604		
	Wiring		WKE94G770		
Standard attachment	Document		Installation Manual		
	Accessory		-		
Optional parts		Joint: CMY-Y102SS/LS-G2 Header: CMY-Y104/108/1010-G			
Remarks		Details on foundation work, duct work, insulation work, electrical wiring, power source switch, and other items shall be referred to the Installation Manual. Due to continuing improvement, above specifications may be subject to change without notice.			

Notes:	Unit converter
1. Nominal cooling conditions (subject to JIS B8615-2) Indoor: 27°C D.B./19°C W.B. (81°F D.B./66°F W.B.), Outdoor: 35°C D.B./24°C W.B. (95°F D.B./75°F W.B.) Pipe length: 7.5 m (24-9/16 ft.), Level difference: 0 m (0 ft.)	BTU/h = kW x 3,412
2. Nominal heating conditions (subject to JIS B8615-2) Indoor: 20°C D.B. (68°F D.B.), Outdoor: 7°C D.B./6°C W.B. (45°F D.B./43°F W.B.) Pipe length: 7.5 m (24-9/16 ft.), Level difference: 0 m (0 ft.)	cfm = m <sup>3</sup> /min x 35.31
3. Nominal heating conditions (subject to JIS B8615-2) Indoor: 20°C D.B. (68°F D.B.), Outdoor: 7°C D.B./6°C W.B. (45°F D.B./43°F W.B.) Pipe length: 7.5 m (24-9/16 ft.), Level difference: 0 m (0 ft.)	lbs = kg/0.4536
4. Cooling mode/Heating mode	
5. The sound pressure level measured by the conventional method in JIS for reference purpose.	
6. External static pressure option is available (30 Pa, 60 Pa, 80 Pa/3.1 mmH <sub>2</sub> O, 6.1 mmH <sub>2</sub> O, 8.2 mmH <sub>2</sub> O). Consult your dealer about the specification when setting External static pressure option.	
7. R32 is flammable, and certain restrictions apply to the installation of units. When installing new units, moving the existing units, or changing the layout of the room, ensure that installation restrictions are observed. For detail, refer to the section in the Databook on installation restrictions.	
8. When connecting the indoor units of M20 or M25, the maximum connectable number of indoor units is 10.	
	*Above specification data is subject to rounding variation.

# 1. SPECIFICATIONS

Y-Series

PUHY-M-YNW-A1, EM-YNW-A1

Model		PUHY-M300YNW-A1 (-BS)		
Power source		3-phase 4-wire 380-400-415 V 50/60 Hz		
Cooling capacity (Nominal)	*1	kW	33.5	
		kcal/h	30,000	
		BTU/h	114,300	
		Power input	kW	8.54
	Current input	A	14.4-13.6-13.2	
	EER	kW/kW	3.92	
	SEER	kW/kW	-	
Temp. range of cooling	Indoor	W.B.	15.0~24.0°C (59~75°F)	
	Outdoor	D.B.	-5.0~52.0°C (23~126°F)	
Heating capacity (Max)	*2	kW	37.5	
		kcal/h	32,300	
		BTU/h	128,000	
	Power input	kW	8.33	
	Current input	A	14.0-13.3-12.8	
	COP	kW/kW	4.50	
	(Nominal)	*3	kW	33.5
			kcal/h	30,000
			BTU/h	114,300
		Power input	kW	7.00
Current input		A	11.8-11.2-10.8	
COP		kW/kW	4.78	
SCOP		kW/kW	-	
Temp. range of heating	Indoor	D.B.	15.0~27.0°C (59~81°F)	
	Outdoor	W.B.	-20.0~15.5°C (-4~60°F)	
Indoor unit connectable	Total capacity	50~130% of outdoor unit capacity		
	*8 Model/Quantity	M20~M140/2~19		
Sound pressure level (measured in anechoic room) *4, 5		dB <A>	61.0/64.5	
Sound power level (measured in anechoic room) *4		dB <A>	80.0/83.5	
Refrigerant piping diameter	Liquid pipe	mm (in.)	9.52 (3/8) Brazed	
	Gas pipe	mm (in.)	22.2 (7/8) Brazed	
FAN	Type x Quantity		Propeller fan x 1	
	Air flow rate	m <sup>3</sup> /min	240	
		L/s	4,000	
		cfm	8,474	
	Control, Driving mechanism		Inverter-control, Direct-driven by motor	
	Motor output	kW	0.92 x 1	
*6 External static press.	0 Pa (0 mmH <sub>2</sub> O)			
Compressor	Type		Inverter scroll hermetic compressor	
	Starting method		Inverter	
	Motor output	kW	6.5	
	Case heater	kW	-	
	Lubricant		MEL46EH	
External finish		Pre-coated galvanized steel sheets (+powder coating for -BS type) <MUNSELL 5Y 8/1 or similar>		
External dimension H x W x D		mm	1,858 (1,798 without legs) x 920 x 740	
		in.	73-3/16 (70-13/16 without legs) x 36-1/4 x 29-3/16	
Protection devices	High pressure protection		High pressure sensor, High pressure switch at 4.15 MPa (601 psi)	
	Inverter circuit (COMP./FAN)		Over-heat protection, Over-current protection	
	Compressor		-	
	Fan motor		-	
Refrigerant	Type x original charge		R32 x 6.5 kg (15 lbs)	
	Control		LEV and HIC circuit	
Net weight		kg (lbs)	223 (492)	
Heat exchanger		Salt-resistant cross fin & copper tube		
HIC circuit (HIC: Heat Inter-Changer)		Copper pipe, tube-in-tube structure		
Defrosting method		Auto-defrost mode (Reversed refrigerant cycle, Hot gas)		
Drawing	External		WKL94T604	
	Wiring		WKE94G770	
Standard attachment	Document		Installation Manual	
	Accessory		-	
Optional parts		Joint: CMY-Y102SS/LS-G2 Header: CMY-Y104/108/1010-G		
Remarks		Details on foundation work, duct work, insulation work, electrical wiring, power source switch, and other items shall be referred to the Installation Manual. Due to continuing improvement, above specifications may be subject to change without notice.		

Notes:	Unit converter
1. Nominal cooling conditions (subject to JIS B8615-2) Indoor: 27°C D.B./19°C W.B. (81°F D.B./66°F W.B.), Outdoor: 35°C D.B./24°C W.B. (95°F D.B./75°F W.B.) Pipe length: 7.5 m (24-9/16 ft.), Level difference: 0 m (0 ft.)	BTU/h =kW x 3,412
2. Nominal heating conditions (subject to JIS B8615-2) Indoor: 20°C D.B. (68°F D.B.), Outdoor: 7°C D.B./6°C W.B. (45°F D.B./43°F W.B.) Pipe length: 7.5 m (24-9/16 ft.), Level difference: 0 m (0 ft.)	cfm =m <sup>3</sup> /min x 35.31
3. Nominal heating conditions (subject to JIS B8615-2) Indoor: 20°C D.B. (68°F D.B.), Outdoor: 7°C D.B./6°C W.B. (45°F D.B./43°F W.B.) Pipe length: 7.5 m (24-9/16 ft.), Level difference: 0 m (0 ft.)	lbs =kg/0.4536
4. Cooling mode/Heating mode	
5. The sound pressure level measured by the conventional method in JIS for reference purpose.	
6. External static pressure option is available (30 Pa, 60 Pa, 80 Pa/3.1 mmH <sub>2</sub> O, 6.1 mmH <sub>2</sub> O, 8.2 mmH <sub>2</sub> O). Consult your dealer about the specification when setting External static pressure option.	
7. R32 is flammable, and certain restrictions apply to the installation of units. When installing new units, moving the existing units, or changing the layout of the room, ensure that installation restrictions are observed. For detail, refer to the section in the Databook on installation restrictions.	
8. When connecting the indoor units of M20 or M25, the maximum connectable number of indoor units is 12.	*Above specification data is subject to rounding variation.

# 1. SPECIFICATIONS

Y-Series

PUHY-M-YNW-A1, EM-YNW-A1

Model		PUHY-EM200YNW-A1 (-BS)			
Power source		3-phase 4-wire 380-400-415 V 50/60 Hz			
Cooling capacity (Nominal)	*1	kW	22.4		
		kcal/h	20,000		
		BTU/h	76,400		
	Power input		kW	4.38	
	Current input		A	7.3-7.0-6.7	
	EER		kW/kW	5.11	
	SEER		kW/kW	-	
Temp. range of cooling	Indoor	W.B.	15.0~24.0°C (59~75°F)		
	Outdoor	D.B.	-5.0~52.0°C (23~126°F)		
Heating capacity (Max)	*2	kW	25.0		
		kcal/h	21,500		
		BTU/h	85,300		
	Power input		kW	4.94	
	Current input		A	8.3-7.9-7.6	
	COP		kW/kW	5.06	
	(Nominal)	*3	kW	22.4	
			kcal/h	20,000	
			BTU/h	76,400	
		Power input		kW	4.26
		Current input		A	7.1-6.8-6.5
		COP		kW/kW	5.25
	SCOP		kW/kW	-	
Temp. range of heating	Indoor	D.B.	15.0~27.0°C (59~81°F)		
	Outdoor	W.B.	-20.0~15.5°C (-4~60°F)		
Indoor unit connectable	Total capacity	50~130% of outdoor unit capacity			
	*8 Model/Quantity	M20~M140/1~13			
Sound pressure level (measured in anechoic room) *4, 5		dB <A>	58.0/59.0		
Sound power level (measured in anechoic room) *4		dB <A>	75.0/78.0		
Refrigerant piping diameter	Liquid pipe	mm (in.)	9.52 (3/8) Brazed		
	Gas pipe	mm (in.)	22.2 (7/8) Brazed		
FAN	Type x Quantity		Propeller fan x 1		
	Air flow rate	m <sup>3</sup> /min	170		
		L/s	2,833		
		cfm	6,003		
	Control, Driving mechanism		Inverter-control, Direct-driven by motor		
	Motor output		kW	0.92 x 1	
*6 External static press.		0 Pa (0 mmH <sub>2</sub> O)			
Compressor	Type		Inverter scroll hermetic compressor		
	Starting method		Inverter		
	Motor output		kW	3.4	
	Case heater		kW	-	
	Lubricant		MEL46EH		
External finish		Pre-coated galvanized steel sheets (+powder coating for -BS type) <MUNSELL 5Y 8/1 or similar>			
External dimension H x W x D		mm	1,858 (1,798 without legs) x 920 x 740		
		in.	73-3/16 (70-13/16 without legs) x 36-1/4 x 29-3/16		
Protection devices	High pressure protection		High pressure sensor, High pressure switch at 4.15 MPa (601 psi)		
	Inverter circuit (COMP./FAN)		Over-heat protection, Over-current protection		
	Compressor		-		
	Fan motor		-		
Refrigerant	Type x original charge		R32 x 6.5 kg (15 lbs)		
	Control		LEV and HIC circuit		
Net weight		kg (lbs)	228 (503)		
Heat exchanger		Salt-resistant cross fin & aluminium tube			
HIC circuit (HIC: Heat Inter-Changer)		Copper pipe, tube-in-tube structure			
Defrosting method		Auto-defrost mode (Reversed refrigerant cycle, Hot gas)			
Drawing	External		WKL94T607		
	Wiring		WKE94G770		
Standard attachment	Document		Installation Manual		
	Accessory		-		
Optional parts		Joint: CMY-Y102SS/LS-G2 Header: CMY-Y104/108/1010-G			
Remarks		Details on foundation work, duct work, insulation work, electrical wiring, power source switch, and other items shall be referred to the Installation Manual. Due to continuing improvement, above specifications may be subject to change without notice.			

Notes:	Unit converter
1. Nominal cooling conditions (subject to JIS B8615-2) Indoor: 27°C D.B./19°C W.B. (81°F D.B./66°F W.B.), Outdoor: 35°C D.B./24°C W.B. (95°F D.B./75°F W.B.) Pipe length: 7.5 m (24-9/16 ft.), Level difference: 0 m (0 ft.)	BTU/h = kW x 3,412
2. Nominal heating conditions (subject to JIS B8615-2) Indoor: 20°C D.B. (68°F D.B.), Outdoor: 7°C D.B./6°C W.B. (45°F D.B./43°F W.B.) Pipe length: 7.5 m (24-9/16 ft.), Level difference: 0 m (0 ft.)	cfm = m <sup>3</sup> /min x 35.31
3. Nominal heating conditions (subject to JIS B8615-2) Indoor: 20°C D.B. (68°F D.B.), Outdoor: 7°C D.B./6°C W.B. (45°F D.B./43°F W.B.) Pipe length: 7.5 m (24-9/16 ft.), Level difference: 0 m (0 ft.)	lbs = kg/0.4536
4. Cooling mode/Heating mode	
5. The sound pressure level measured by the conventional method in JIS for reference purpose.	
6. External static pressure option is available (30 Pa, 60 Pa, 80 Pa/3.1 mmH <sub>2</sub> O, 6.1 mmH <sub>2</sub> O, 8.2 mmH <sub>2</sub> O). Consult your dealer about the specification when setting External static pressure option.	
7. R32 is flammable, and certain restrictions apply to the installation of units. When installing new units, moving the existing units, or changing the layout of the room, ensure that installation restrictions are observed. For detail, refer to the section in the Databook on installation restrictions.	
8. When connecting the indoor units of M20 or M25, the maximum connectable number of indoor units is 8.	
	*Above specification data is subject to rounding variation.

# 1. SPECIFICATIONS

Y-Series

PUHY-M-YNW-A1, EM-YNW-A1

Model		PUHY-EM250YNW-A1 (-BS)		
Power source		3-phase 4-wire 380-400-415 V 50/60 Hz		
Cooling capacity (Nominal)	*1	kW	28.0	
		kcal/h	25,000	
		BTU/h	95,500	
	Power input	kW	6.36	
	Current input	A	10.7-10.1-9.8	
	EER	kW/kW	4.40	
	SEER	kW/kW	-	
Temp. range of cooling	Indoor	W.B.	15.0~24.0°C (59~75°F)	
	Outdoor	D.B.	-5.0~52.0°C (23~126°F)	
Heating capacity (Max)	*2	kW	31.5	
		kcal/h	27,100	
		BTU/h	107,500	
	Power input	kW	6.92	
	Current input	A	11.6-11.0-10.6	
	COP	kW/kW	4.55	
	(Nominal)	*3	kW	28.0
			kcal/h	25,000
			BTU/h	95,500
		Power input	kW	5.83
Current input		A	9.8-9.3-9.0	
COP		kW/kW	4.80	
SCOP		kW/kW	-	
Temp. range of heating	Indoor	D.B.	15.0~27.0°C (59~81°F)	
	Outdoor	W.B.	-20.0~15.5°C (-4~60°F)	
Indoor unit connectable	Total capacity	50~130% of outdoor unit capacity		
	*8 Model/Quantity	M20~M140/1~16		
Sound pressure level (measured in anechoic room) *4, 5		dB <A>	60.0/61.0	
Sound power level (measured in anechoic room) *4		dB <A>	78.0/80.0	
Refrigerant piping diameter	Liquid pipe	mm (in.)	9.52 (3/8) Brazed	
	Gas pipe	mm (in.)	22.2 (7/8) Brazed	
FAN	Type x Quantity		Propeller fan x 1	
	Air flow rate	m <sup>3</sup> /min	185	
		L/s	3,083	
		cfm	6,532	
	Control, Driving mechanism		Inverter-control, Direct-driven by motor	
	Motor output	kW	0.92 x 1	
*6 External static press.	0 Pa (0 mmH <sub>2</sub> O)			
Compressor	Type	Inverter scroll hermetic compressor		
	Starting method	Inverter		
	Motor output	kW	5.1	
	Case heater	kW	-	
	Lubricant	MEL46EH		
External finish		Pre-coated galvanized steel sheets (+powder coating for -BS type) <MUNSELL 5Y 8/1 or similar>		
External dimension H x W x D		mm	1,858 (1,798 without legs) x 920 x 740	
		in.	73-3/16 (70-13/16 without legs) x 36-1/4 x 29-3/16	
Protection devices	High pressure protection		High pressure sensor, High pressure switch at 4.15 MPa (601 psi)	
	Inverter circuit (COMP./FAN)		Over-heat protection, Over-current protection	
	Compressor		-	
	Fan motor		-	
Refrigerant	Type x original charge		R32 x 6.5 kg (15 lbs)	
	Control		LEV and HIC circuit	
Net weight		kg (lbs)	228 (503)	
Heat exchanger		Salt-resistant cross fin & aluminium tube		
HIC circuit (HIC: Heat Inter-Changer)		Copper pipe, tube-in-tube structure		
Defrosting method		Auto-defrost mode (Reversed refrigerant cycle, Hot gas)		
Drawing	External	WKL94T607		
	Wiring	WKE94G770		
Standard attachment	Document	Installation Manual		
	Accessory	-		
Optional parts		Joint: CMY-Y102SS/LS-G2 Header: CMY-Y104/108/1010-G		
Remarks		Details on foundation work, duct work, insulation work, electrical wiring, power source switch, and other items shall be referred to the Installation Manual. Due to continuing improvement, above specifications may be subject to change without notice.		

Notes:	Unit converter
1. Nominal cooling conditions (subject to JIS B8615-2) Indoor: 27°C D.B./19°C W.B. (81°F D.B./66°F W.B.), Outdoor: 35°C D.B./24°C W.B. (95°F D.B./75°F W.B.) Pipe length: 7.5 m (24-9/16 ft.), Level difference: 0 m (0 ft.)	BTU/h =kW x 3,412
2. Nominal heating conditions (subject to JIS B8615-2) Indoor: 20°C D.B. (68°F D.B.), Outdoor: 7°C D.B./6°C W.B. (45°F D.B./43°F W.B.) Pipe length: 7.5 m (24-9/16 ft.), Level difference: 0 m (0 ft.)	cfm =m <sup>3</sup> /min x 35.31
3. Nominal heating conditions (subject to JIS B8615-2) Indoor: 20°C D.B. (68°F D.B.), Outdoor: 7°C D.B./6°C W.B. (45°F D.B./43°F W.B.) Pipe length: 7.5 m (24-9/16 ft.), Level difference: 0 m (0 ft.)	lbs =kg/0.4536
4. Cooling mode/Heating mode	
5. The sound pressure level measured by the conventional method in JIS for reference purpose.	
6. External static pressure option is available (30 Pa, 60 Pa, 80 Pa/3.1 mmH <sub>2</sub> O, 6.1 mmH <sub>2</sub> O, 8.2 mmH <sub>2</sub> O). Consult your dealer about the specification when setting External static pressure option.	
7. R32 is flammable, and certain restrictions apply to the installation of units. When installing new units, moving the existing units, or changing the layout of the room, ensure that installation restrictions are observed. For detail, refer to the section in the Databook on installation restrictions.	
8. When connecting the indoor units of M20 or M25, the maximum connectable number of indoor units is 10.	*Above specification data is subject to rounding variation.



# 1. SPECIFICATIONS

Y-Series

PUHY-M-YNW-A1, EM-YNW-A1

Model		PUHY-EM300YNW-A1 (-BS)			
Power source		3-phase 4-wire 380-400-415 V 50/60 Hz			
Cooling capacity (Nominal)	*1	kW	33.5		
		kcal/h	30,000		
		BTU/h	114,300		
	Power input	kW	7.44		
		Current input	A	12.5-11.9-11.5	
		EER	kW/kW	4.50	
SEER		kW/kW	-		
Temp. range of cooling	Indoor	W.B.	15.0~24.0°C (59~75°F)		
	Outdoor	D.B.	-5.0~52.0°C (23~126°F)		
Heating capacity (Max)	*2	kW	37.5		
		kcal/h	32,300		
		BTU/h	128,000		
	Power input	kW	7.94		
		Current input	A	13.4-12.7-12.2	
		COP	kW/kW	4.72	
	(Nominal)	*3	kW	33.5	
			kcal/h	30,000	
			BTU/h	114,300	
		Power input	kW	6.67	
			Current input	A	11.2-10.6-10.3
			COP	kW/kW	5.02
SCOP		kW/kW	-		
Temp. range of heating	Indoor	D.B.	15.0~27.0°C (59~81°F)		
	Outdoor	W.B.	-20.0~15.5°C (-4~60°F)		
Indoor unit connectable	Total capacity	50~130% of outdoor unit capacity			
	*8 Model/Quantity	M20~M140/2~19			
Sound pressure level (measured in anechoic room) *4, 5		dB <A>	61.0/64.5		
Sound power level (measured in anechoic room) *4		dB <A>	80.0/83.5		
Refrigerant piping diameter	Liquid pipe	mm (in.)	9.52 (3/8) Brazed		
	Gas pipe	mm (in.)	28.58 (1-1/8) Brazed		
FAN	Type x Quantity		Propeller fan x 1		
	Air flow rate	m <sup>3</sup> /min	240		
		L/s	4,000		
		cfm	8,474		
	Control, Driving mechanism		Inverter-control, Direct-driven by motor		
	Motor output	kW	0.92 x 1		
*6 External static press.	0 Pa (0 mmH <sub>2</sub> O)				
Compressor	Type		Inverter scroll hermetic compressor		
	Starting method		Inverter		
	Motor output	kW	6.0		
	Case heater	kW	-		
	Lubricant		MEL46EH		
External finish		Pre-coated galvanized steel sheets (+powder coating for -BS type) <MUNSELL 5Y 8/1 or similar>			
External dimension H x W x D		mm	1,858 (1,798 without legs) x 920 x 740		
		in.	73-3/16 (70-13/16 without legs) x 36-1/4 x 29-3/16		
Protection devices	High pressure protection		High pressure sensor, High pressure switch at 4.15 MPa (601 psi)		
	Inverter circuit (COMP./FAN)		Over-heat protection, Over-current protection		
	Compressor		-		
	Fan motor		-		
Refrigerant	Type x original charge		R32 x 6.5 kg (15 lbs)		
	Control		LEV and HIC circuit		
Net weight		kg (lbs)	229 (505)		
Heat exchanger		Salt-resistant cross fin & aluminium tube			
HIC circuit (HIC: Heat Inter-Changer)		Copper pipe, tube-in-tube structure			
Defrosting method		Auto-defrost mode (Reversed refrigerant cycle, Hot gas)			
Drawing	External		WKL94T607		
	Wiring		WKE94G770		
Standard attachment	Document		Installation Manual		
	Accessory		-		
Optional parts		Joint: CMY-Y102SS/LS-G2 Header: CMY-Y104/108/1010-G			
Remarks		Details on foundation work, duct work, insulation work, electrical wiring, power source switch, and other items shall be referred to the Installation Manual. Due to continuing improvement, above specifications may be subject to change without notice.			

Notes:	Unit converter
1. Nominal cooling conditions (subject to JIS B8615-2) Indoor: 27°C D.B./19°C W.B. (81°F D.B./66°F W.B.), Outdoor: 35°C D.B./24°C W.B. (95°F D.B./75°F W.B.) Pipe length: 7.5 m (24-9/16 ft.), Level difference: 0 m (0 ft.)	BTU/h = kW x 3,412
2. Nominal heating conditions (subject to JIS B8615-2) Indoor: 20°C D.B. (68°F D.B.), Outdoor: 7°C D.B./6°C W.B. (45°F D.B./43°F W.B.) Pipe length: 7.5 m (24-9/16 ft.), Level difference: 0 m (0 ft.)	cfm = m <sup>3</sup> /min x 35.31
3. Nominal heating conditions (subject to JIS B8615-2) Indoor: 20°C D.B. (68°F D.B.), Outdoor: 7°C D.B./6°C W.B. (45°F D.B./43°F W.B.) Pipe length: 7.5 m (24-9/16 ft.), Level difference: 0 m (0 ft.)	lbs = kg/0.4536
4. Cooling mode/Heating mode	
5. The sound pressure level measured by the conventional method in JIS for reference purpose.	
6. External static pressure option is available (30 Pa, 60 Pa, 80 Pa/3.1 mmH <sub>2</sub> O, 6.1 mmH <sub>2</sub> O, 8.2 mmH <sub>2</sub> O). Consult your dealer about the specification when setting External static pressure option.	
7. R32 is flammable, and certain restrictions apply to the installation of units. When installing new units, moving the existing units, or changing the layout of the room, ensure that installation restrictions are observed. For detail, refer to the section in the Databook on installation restrictions.	
8. When connecting the indoor units of M20 or M25, the maximum connectable number of indoor units is 12.	
	*Above specification data is subject to rounding variation.

PUHY-M200, 250, 300YNW-A1(-BS)

Unit: mm

- Note 1. Please refer to the next page for information regarding necessary spacing around the unit and foundation work.  
 2. The detachable leg can be removed at site.  
 3. At brazing of pipes, wrap the refrigerant service valve with wet cloth and keep the temperature of refrigerant service valve under 120°C.  
 4. This unit has restrictions for the safety, so refer to SAFETY HANDLING FOR R32 or the Installation Manual.

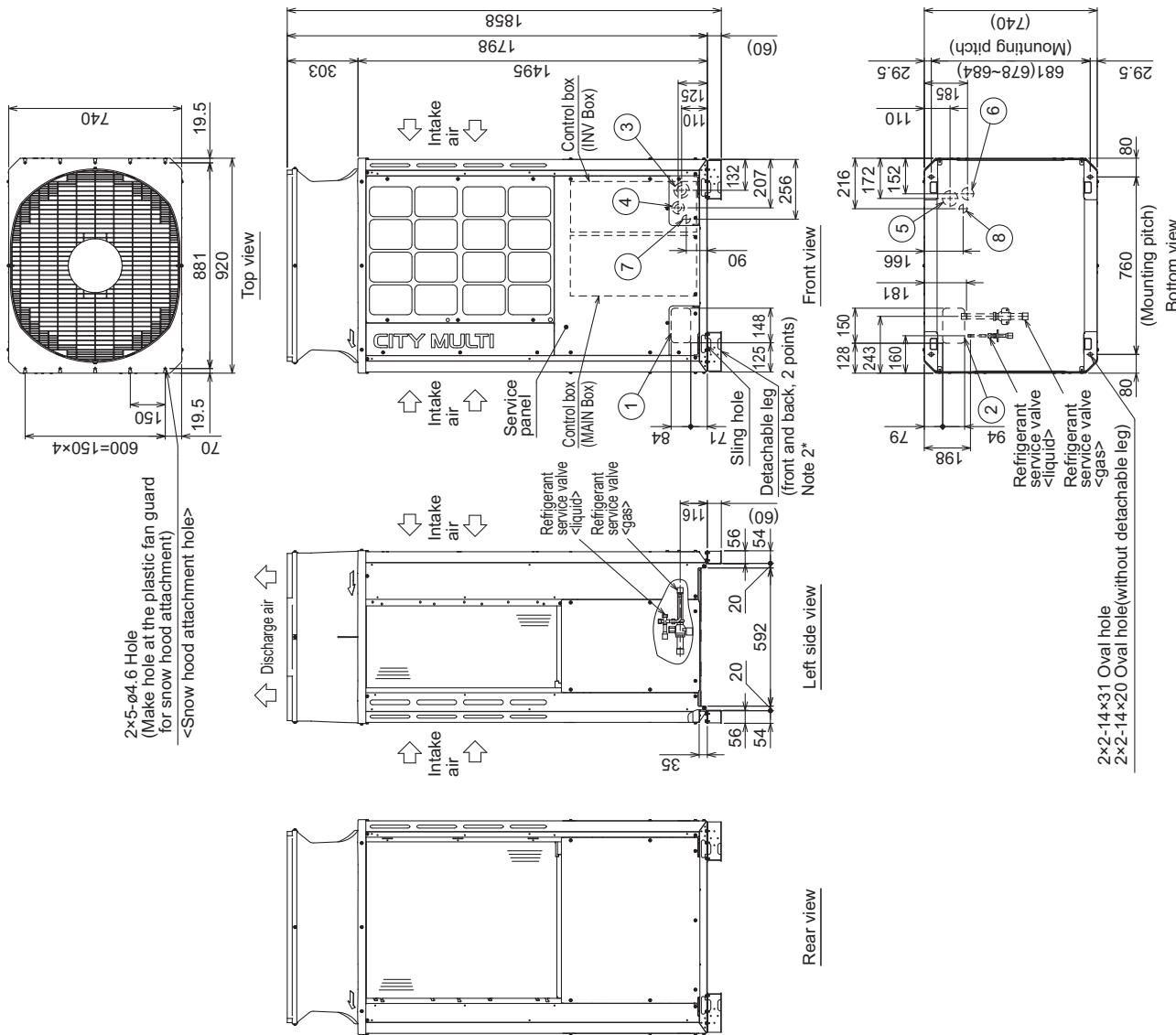

Connecting pipe specifications

Model	Refrigerant pipe		Diameter	
	Liquid	Gas	Liquid	Gas
M200	ø9.52 Brazed	ø22.2 Brazed	ø9.52	ø22.2
M250				
M300				

NO.	Usage	Specifications	
		Front through hole	Bottom through hole
①	For pipes	148 x 84 Knockout hole	150 x 94 Knockout hole
②		150 x 94 Knockout hole	165 or ø40 Knockout hole
③	For wires	ø52 or ø27 Knockout hole	ø65 Knockout hole
④		ø52 or ø27 Knockout hole	ø65 Knockout hole
⑤	For transmission cables	ø52 Knockout hole	ø63 Knockout hole
⑥		ø52 Knockout hole	ø63 Knockout hole
⑦	For transmission cables	ø34 Knockout hole	ø34 Knockout hole
⑧		ø34 Knockout hole	ø34 Knockout hole

PUHY-M200, 250, 300YNW-A1(-BS)

Unit: mm

1. Required space around the unit

● In case of single installation

① Secure enough space around the unit as shown in the figure below.

- With a space of at least 300mm to the wall on the back of the unit
- With a space of at least 100mm to the wall on the front of the unit

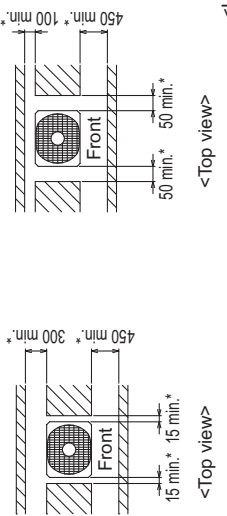

② When the height of the walls on the front, back or on the sides<H> exceeds the wall height limit as defined below, add the height that exceeds the height limit <h> to the figures that are marked with an asterisk.

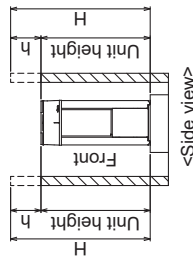

<Wall height limit> Front :Up to the unit height  
Back :Up to the unit height  
Side :Up to the unit height

2. Foundation work

- ① Take into consideration the surface strength, water drainage route, piping route, and wiring route when preparing the installation site.  
<Note that the drain water comes out of the unit during operation.>
- ② Build the foundation in such way that the corner of the installation leg is securely supported as shown in the right figure.(Fig.A,B)  
When using a rubber isolating cushion, please ensure it is large enough to cover the entire width of each of the unit's legs.
- ③ The protrusion length of the anchor bolt must not exceed 30mm.(Fig.A,B)
- ④ Use four fixing plates as shown in the right figure <field supply required> when using post-installed anchor bolts.(Fig. C, D)
- ⑤ To prevent small animals and water and snow from entering the unit and damaging its parts, close the gap around the edges of through holes for pipes and wires with filler plates <field supply required>.
- ⑥ When the pipes or cables are routed at the bottom of the unit, make sure that the through hole at the base of the unit does not get blocked with the installation base.
- ⑦ Refer to the Installation Manual when installing units on an installation base.

● In case of collective installation

- ① When multiple units are installed adjacent to each other, secure enough space to allow for air circulation and walkway between groups of units as shown in the figures below.
- ② At least two sides must be left open.
- ③ As with the single installation, add the height that exceeds the height limit<h> to the figures that are marked with an asterisk.
- ④ If there is a wall at both the front and the rear of the unit, install up to six units consecutively in the side direction and provide a space of 1000mm or more as inlet space/ passage space for each six units.

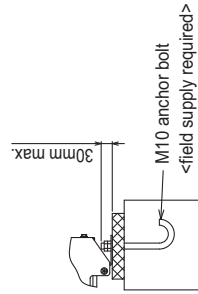
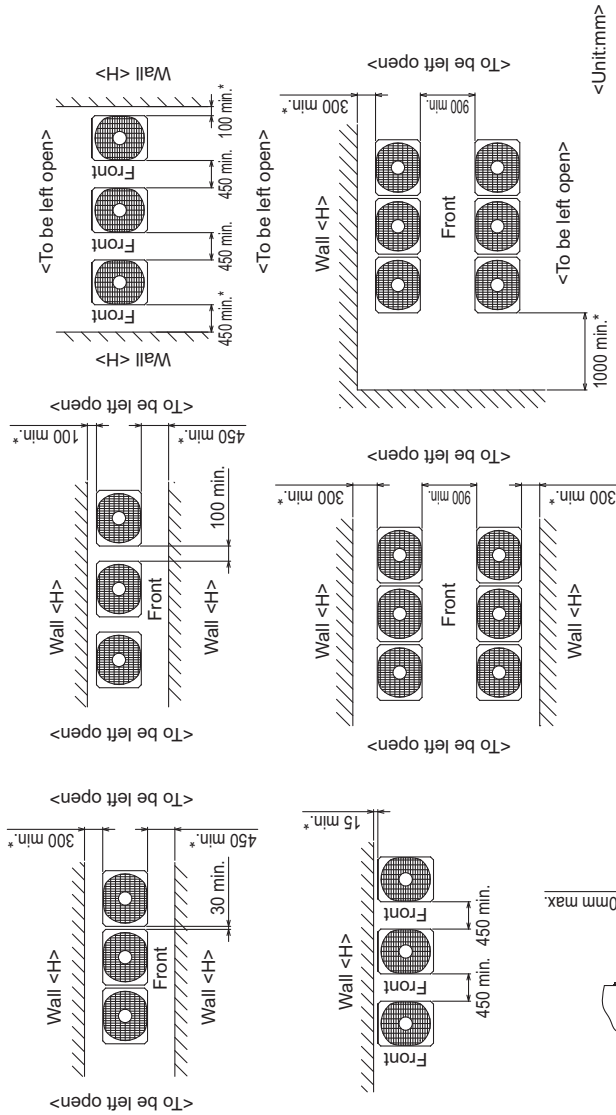

Fig.A (without detachable legs)



Fig.C (without detachable legs)

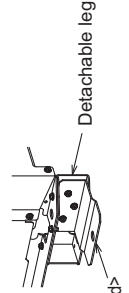

Fig.D (with detachable legs)

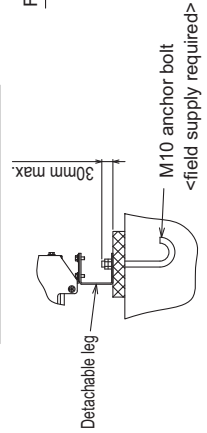
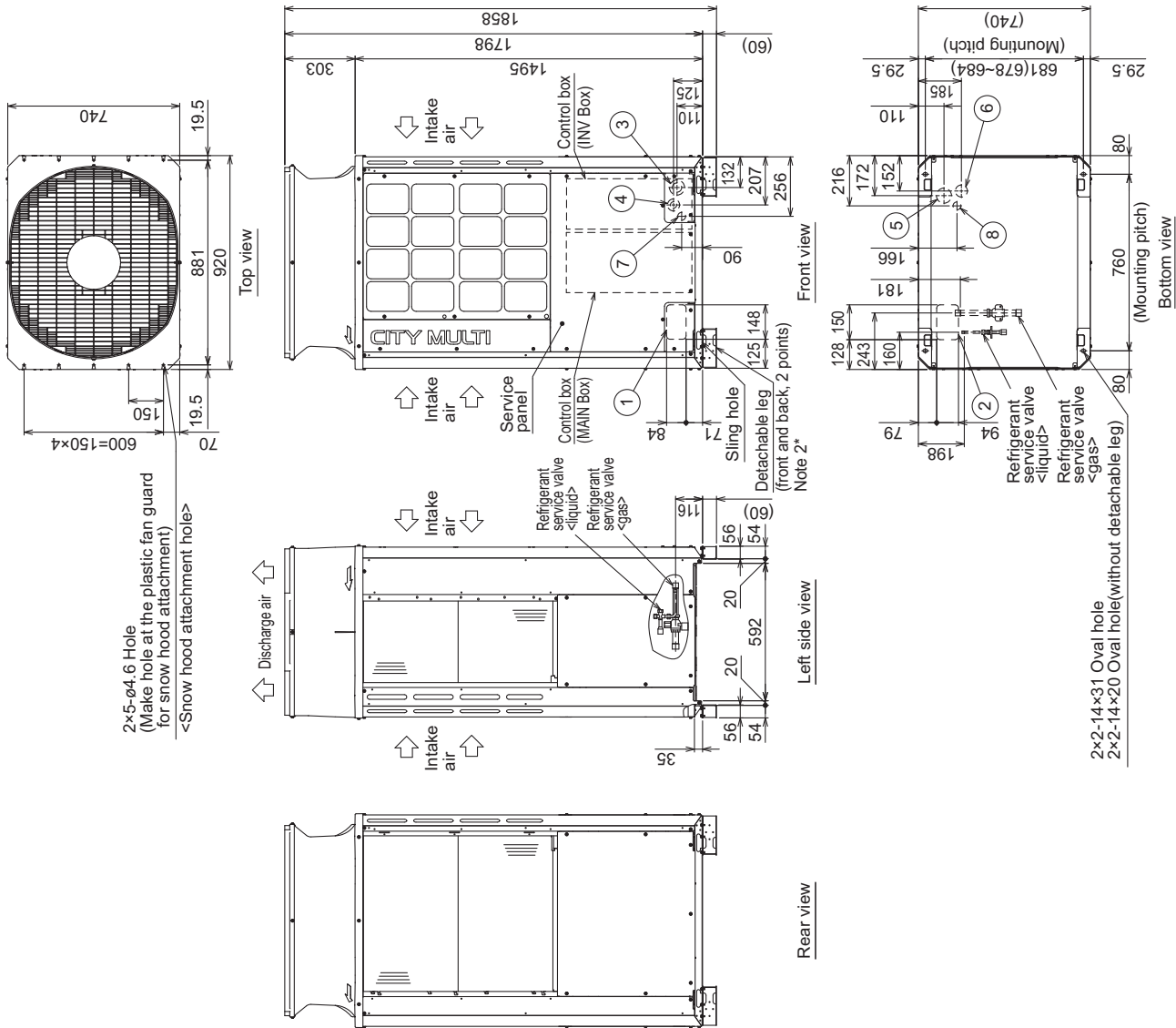

Fig.B (with detachable legs)

PUHY-EM200, 250, 300YNW-A1(-BS)

Unit: mm

- Note 1. Please refer to the next page for information regarding necessary spacing around the unit and foundation work.  
 2. The detachable leg can be removed at site.  
 3. At brazing of pipes, wrap the refrigerant service valve with wet cloth and keep the temperature of refrigerant service valve under 120°C.  
 4. This unit has restrictions for the safety, so refer to SAFETY HANDLING FOR R32 or the Installation Manual.



Connecting pipe specifications

Model	Refrigerant pipe		Diameter	
	Liquid	Gas	Liquid	Gas
EM200	ø9.52 Brazed	ø22.2 Brazed	ø9.52	ø22.2
EM250				
EM300	ø28.58 Brazed			

NO.	Usage	Specifications	
		Front through hole	Bottom through hole
①	For pipes	148 x 84 Knockout hole	150 x 94 Knockout hole
②		150 x 94 Knockout hole	148 x 84 Knockout hole
③	For wires	ø65 or ø40 Knockout hole	ø65 or ø40 Knockout hole
④		ø52 or ø27 Knockout hole	ø52 or ø27 Knockout hole
⑤	For transmission cables	ø65 Knockout hole	ø65 Knockout hole
⑥		ø52 Knockout hole	ø52 Knockout hole
⑦	For transmission cables	ø34 Knockout hole	ø34 Knockout hole
⑧		ø34 Knockout hole	ø34 Knockout hole

PUHY-EM200, 250, 300YNW-A1(-BS)

Unit: mm

1. Required space around the unit

● In case of single installation

① Secure enough space around the unit as shown in the figure below.

- With a space of at least 300mm to the wall on the back of the unit
- With a space of at least 100mm to the wall on the front of the unit

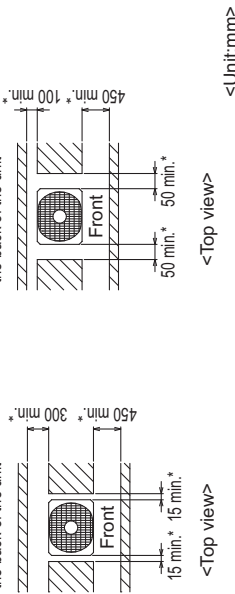

② When the height of the walls on the front, back or on the sides<H> exceeds the wall height limit as defined below add the height that exceeds the height limit <h> to the figures that are marked with an asterisk.

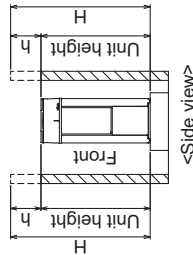

<Wall height limit> Front :Up to the unit height  
Back :Up to the unit height  
Side :Up to the unit height

2. Foundation work

- Take into consideration the surface strength, water drainage route, piping route, and wiring route when preparing the installation site.  
<Note that the drain water comes out of the unit during operation.>
- Build the foundation in such way that the corner of the installation leg is securely supported as shown in the right figure.(Fig.A,B)  
When using a rubber isolating cushion, please ensure it is large enough to cover the entire width of each of the unit's legs.
- The protrusion length of the anchor bolt must not exceed 30mm.(Fig.A,B)
- Use four fixing plates as shown in the right figure <field supply required> when using post-installed anchor bolts.(Fig. C, D)
- To prevent small animals and water and snow from entering the unit and damaging its parts, close the gap around the edges of through holes for pipes and wires with filler plates <field supply required>.
- When the pipes or cables are routed at the bottom of the unit, make sure that the through hole at the base of the unit does not get blocked with the installation base.
- Refer to the Installation Manual when installing units on an installation base.

● In case of collective installation

- When multiple units are installed adjacent to each other, secure enough space to allow for air circulation and walkway between groups of units as shown in the figures below.
- At least two sides must be left open.
- As with the single installation, add the height that exceeds the height limit<h> to the figures that are marked with an asterisk.
- If there is a wall at both the front and the rear of the unit, install up to six units consecutively in the side direction and provide a space of 1000mm or more as inlet space/ passage space for each six units.

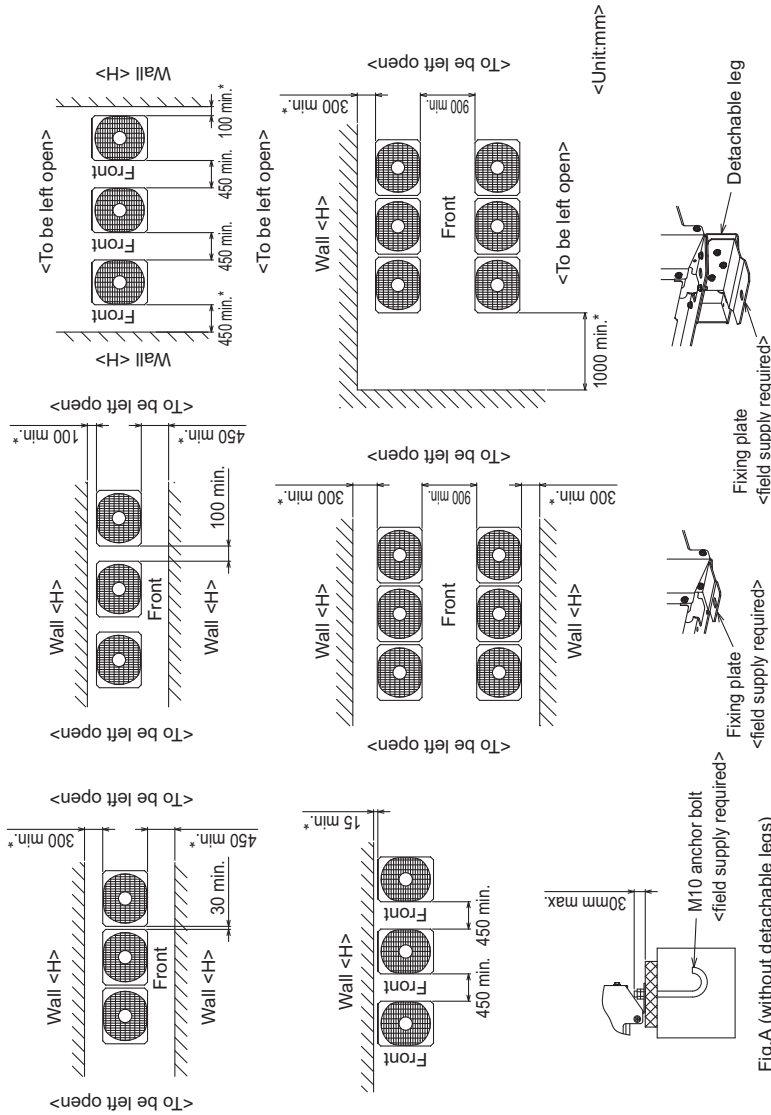

Fig.A (without detachable legs)

Fig.B (with detachable legs)

Fig.C (without detachable legs)

Fig.D (with detachable legs)

PUHY-M-YNW-A1, EM-YNW-A1

PUHY-M200, 250, 300YNW-A1 (-BS)

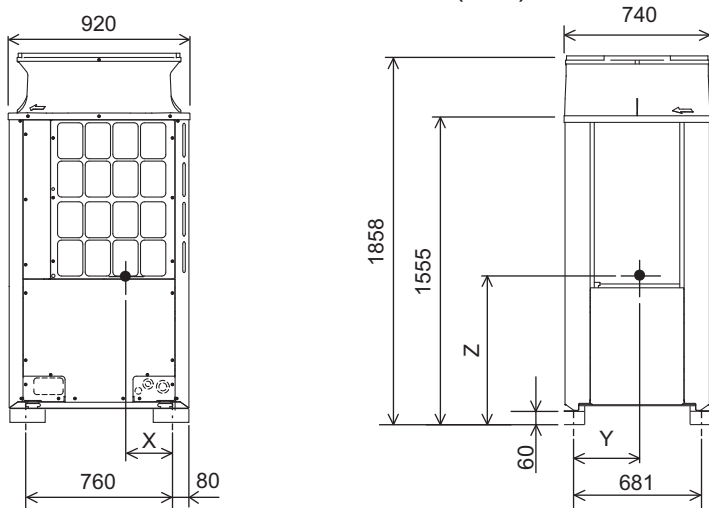

Unit: mm

Model	X	Y	Z
PUHY-M200YNW-A1(-BS)	348	338	680
PUHY-M250YNW-A1(-BS)	348	338	680
PUHY-M300YNW-A1(-BS)	349	338	676

PUHY-EM200, 250, 300YNW-A1 (-BS)

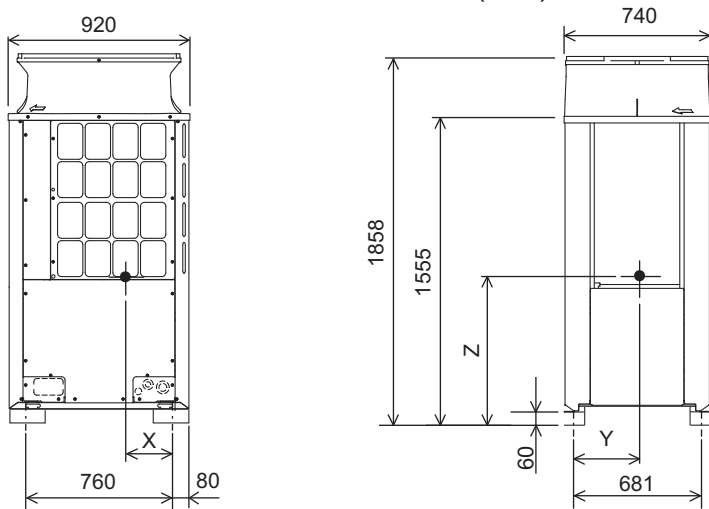

Unit: mm

Model	X	Y	Z
PUHY-EM200YNW-A1(-BS)	349	337	686
PUHY-EM250YNW-A1(-BS)	349	337	686
PUHY-EM300YNW-A1(-BS)	351	338	682

PUHY-(E)M200, 250, 300YNW-A1(-BS)

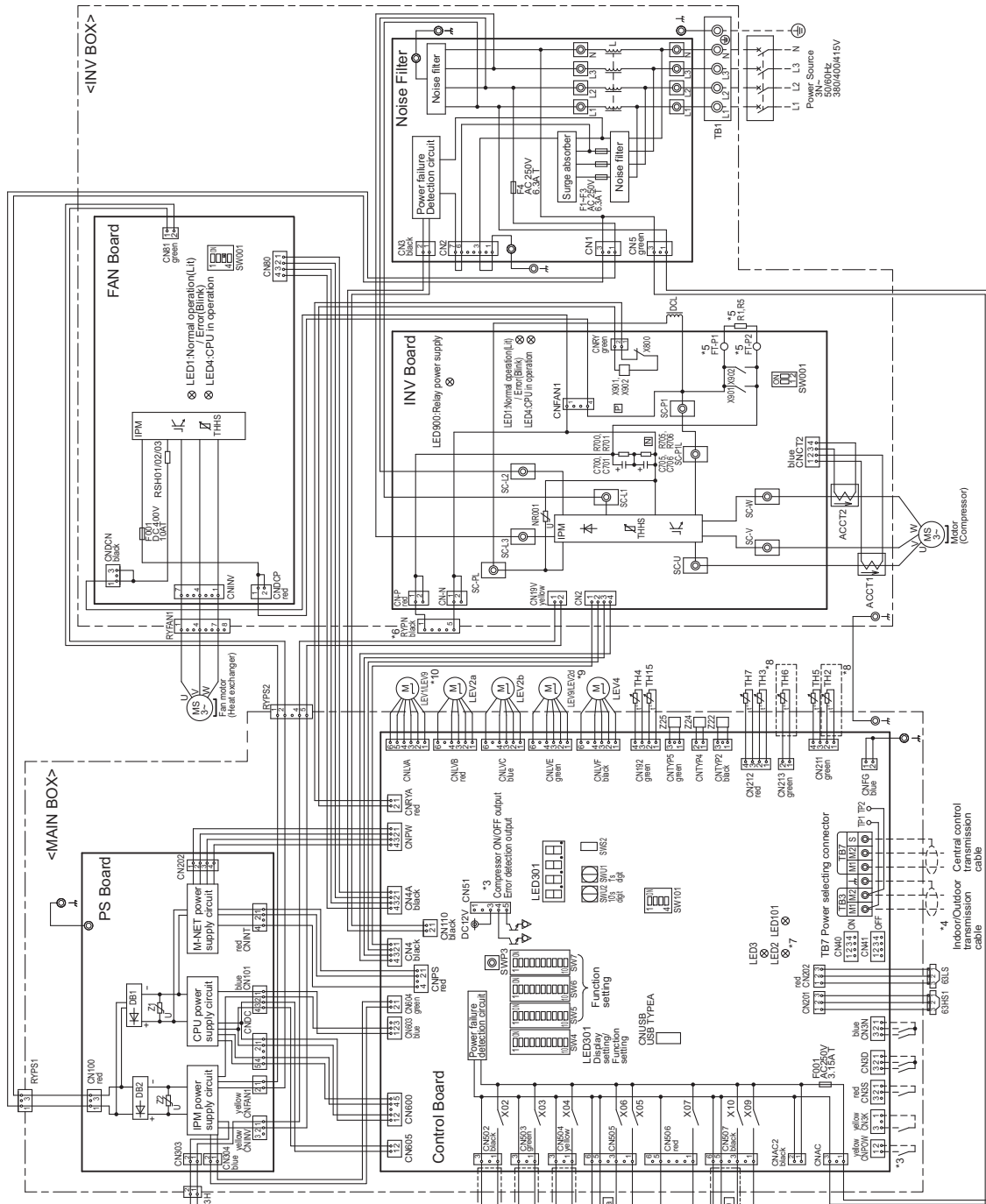

- \*1. Single-dotted lines indicate wiring not supplied with the unit.
- \*2. Dot-dash lines indicate the control box boundaries.
- \*3. Refer to the Data book for connecting input/output signal connectors.
- \*4. Daisy-chain terminals (TB3) on the outdoor units in the same refrigerant system (TB3) have a locking function.
- \*5. Faston terminals have a locking function. Make sure the terminals are securely locked in place after insertion. Press the tab on the terminals to removed them.
- \*6. Control box houses high-voltage parts. Before inspecting the inside of the MAIN BOX or INV BOX, turn off the power, keep the unit off for at least 10 minutes, and confirm that the voltage of the connector RYPN on INV BOX has dropped to DC20V or less.
- \*7. Control board LED display.

LED3	Normal operation (L) Error (Blink)
LED2	SW6-10 is Off and In operation (L) In stop (Unit)
LED1	SW6-10 is ON Function setting by SW4 enable (L) / Disable (Unit)

LED3	Normal operation (L) / Error (Blink)
LED2	SW6-10 is ON Function setting by SW4 enable (L) / Disable (Unit)
LED1	Normal operation (L) / Error (Unit)

Model name / Appliance	PUHY-M-YNW-A1
Model name / Appliance	EM-YNW-A1

Model name / Appliance	PUHY-E-M200
Model name / Appliance	PUHY-E-M250
Model name / Appliance	PUHY-E-M300

Model name / Appliance	PUHY-E-M200
Model name / Appliance	PUHY-E-M250
Model name / Appliance	PUHY-E-M300

Model name / Appliance	PUHY-E-M200
Model name / Appliance	PUHY-E-M250
Model name / Appliance	PUHY-E-M300

Model name / Appliance	PUHY-E-M200
Model name / Appliance	PUHY-E-M250
Model name / Appliance	PUHY-E-M300

Model name / Appliance	PUHY-E-M200
Model name / Appliance	PUHY-E-M250
Model name / Appliance	PUHY-E-M300

<Symbol explanation>

Symbol	Explanation
Z1S4a	Cooling/Heating switching
Z1S4b	Heat exchanger capacity control (only PUHY model)
63H1	Pressure switch
63H5	High/low pressure protection for the outdoor unit
63LS	Discharge pressure sensor
C100, C200, C300, C400	Capacitor (in water main circuit)
DCL	DC reactor
LEV1-10	Choke coil (for high frequency noise reduction)
LEV2a, b	HIC bypass: Controls refrigerant flow in HIC circuit
LEV2c-9	Pressure control Refrigerant flow rate control
LEV4	Pressure control Refrigerant flow rate control
RT.5	For opening/closing the injection circuit
RSHD10203	For opening/closing for inverter
SV1a	Heat exchanger prevention
SV2	For current detection
SV3	For opening/closing the bypass circuit under the O/S
SV4	For opening/closing the discharge
SV4.0-8	For opening/closing the bypass circuit
SV4.0-9	For opening/closing the bypass circuit (cooling/heating)
SV4.15-11	For opening/closing the bypass circuit (cooling/heating)
TB1	Terminal
TB3	Indoor/outdoor transmission line block
TB7	Central control transmission line block
TH2-8	Subcool bypass outlet temperature
TH4	High side pipe temperature
TH5	ACC inlet pipe temperature
TH6-8	Subcooled liquid refrigerant temperature
TH7	Oil temperature
TH15	Compressor stiel bottom temperature
TH15	IPM temperature
X301, 302	Magnetic relay (inverter main circuit)
ZZZ, Z4, Z5	Function setting connector

5-1. Sound levels in cooling mode

PUHY-M-YNW-A1, EM-YNW-A1

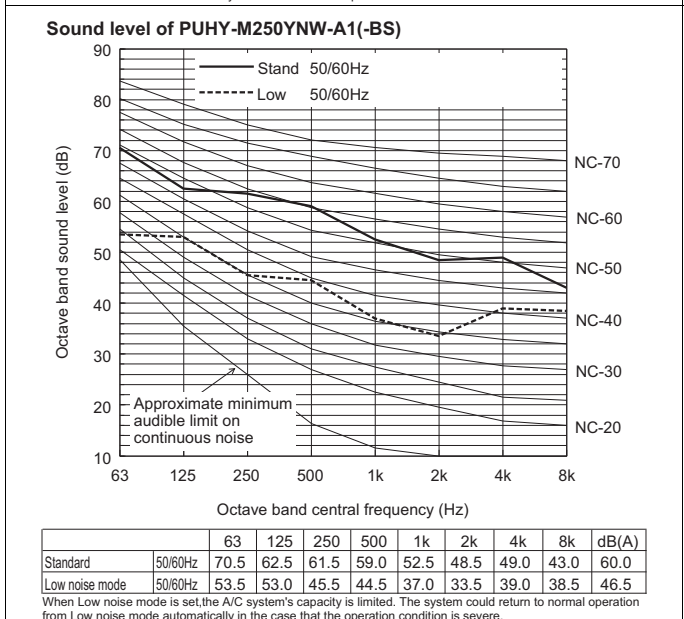
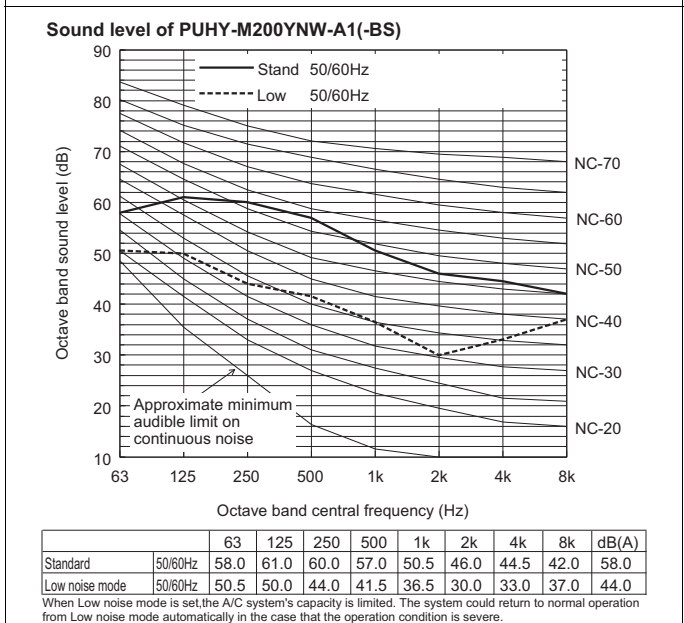
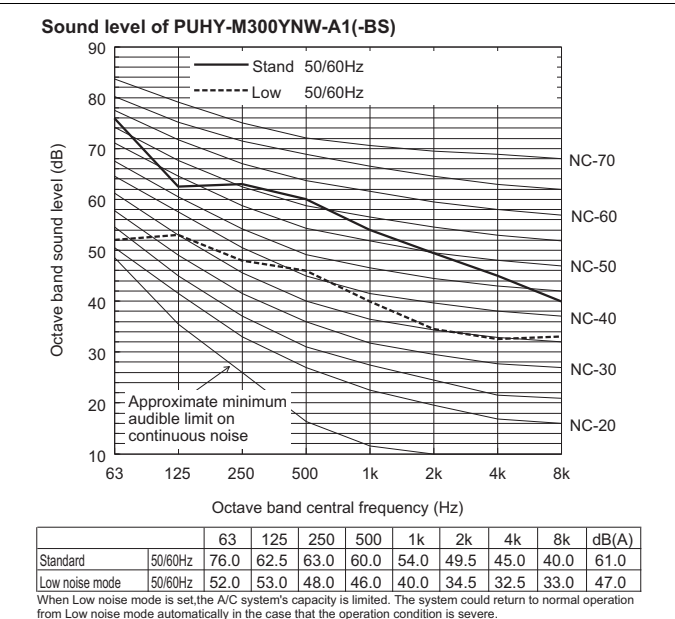
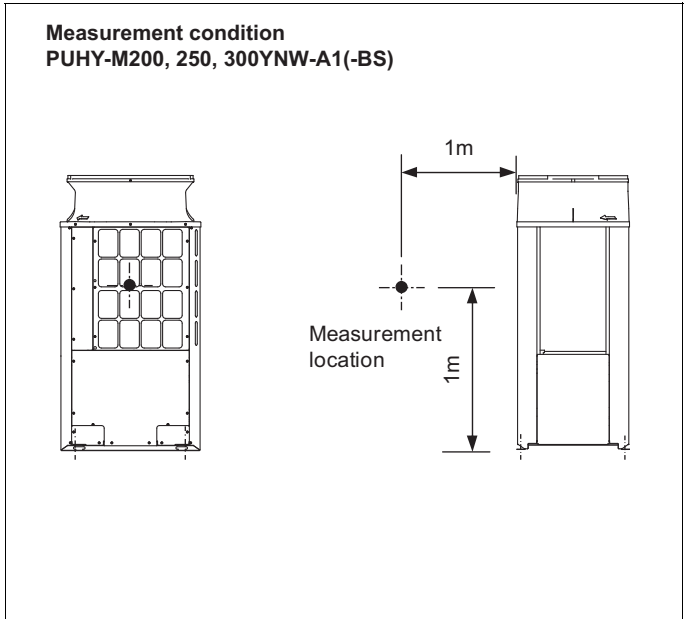

• Depending on the operation conditions, the unit generates noise caused by valve actuation, refrigerant flow, and pressure changes when operating normally. Please consider to avoid location where quietness is required. The sound pressure level measured by the conventional method in JIS for reference purpose.



**Measurement condition**  
**PUHY-EM200, 250, 300YNW-A1(-BS)**

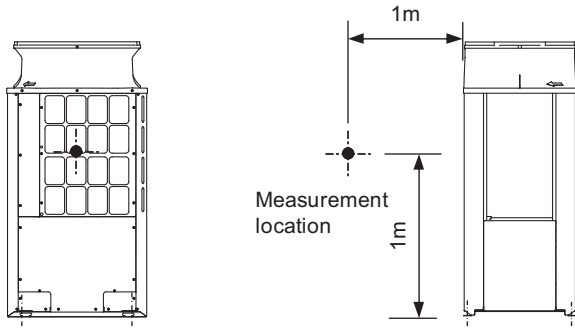

**Sound level of PUHY-EM300YNW-A1(-BS)**

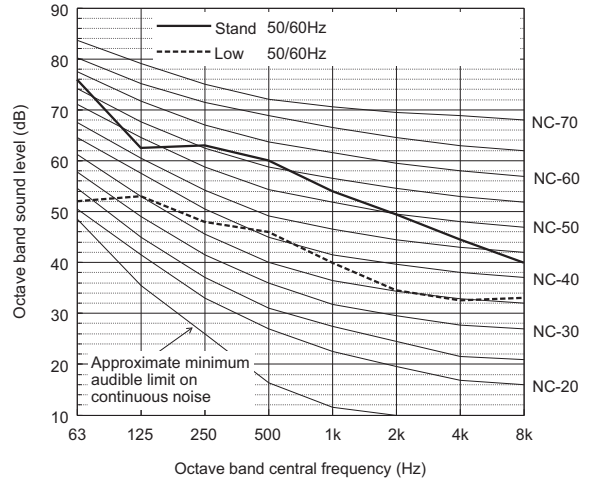

		63	125	250	500	1k	2k	4k	8k	dB(A)
Standard	50/60Hz	76.0	62.5	63.0	60.0	54.0	49.5	44.5	40.0	61.0
Low noise mode	50/60Hz	52.0	53.0	48.0	46.0	40.0	34.5	32.5	33.0	47.0

When Low noise mode is set, the A/C system's capacity is limited. The system could return to normal operation from Low noise mode automatically in the case that the operation condition is severe.

**Sound level of PUHY-EM200YNW-A1(-BS)**

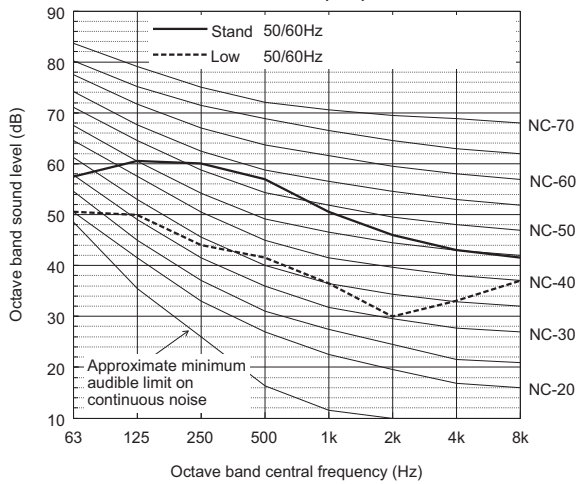

		63	125	250	500	1k	2k	4k	8k	dB(A)
Standard	50/60Hz	57.5	60.5	60.0	57.0	50.5	46.0	43.0	41.5	58.0
Low noise mode	50/60Hz	50.5	50.0	44.0	41.5	36.5	30.0	33.0	37.0	44.0

When Low noise mode is set, the A/C system's capacity is limited. The system could return to normal operation from Low noise mode automatically in the case that the operation condition is severe.

**Sound level of PUHY-EM250YNW-A1(-BS)**

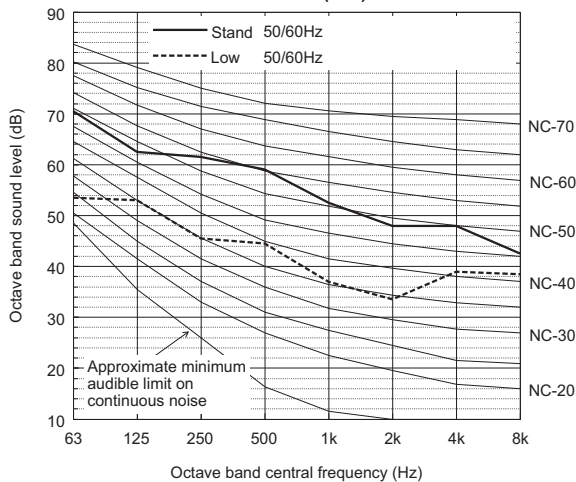

		63	125	250	500	1k	2k	4k	8k	dB(A)
Standard	50/60Hz	70.5	62.5	61.5	59.0	52.5	48.0	48.0	42.5	60.0
Low noise mode	50/60Hz	53.5	53.0	45.5	44.5	37.0	33.5	39.0	38.5	46.5

When Low noise mode is set, the A/C system's capacity is limited. The system could return to normal operation from Low noise mode automatically in the case that the operation condition is severe.

- Depending on the operation conditions, the unit generates noise caused by valve actuation, refrigerant flow, and pressure changes when operating normally. Please consider to avoid location where quietness is required. The sound pressure level measured by the conventional method in JIS for reference purpose.

PUHY-M-YNW-A1, EM-YNW-A1

5-2. Sound levels in heating mode

Measurement condition  
PUHY-M200, 250, 300YNW-A1(-BS)

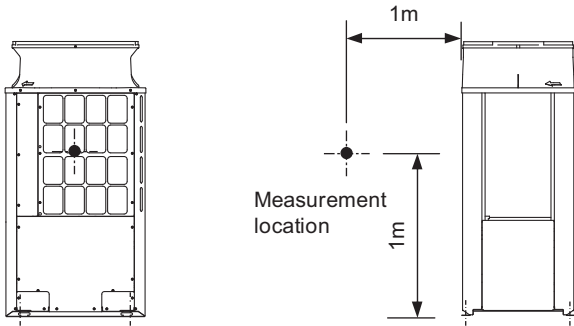

Sound level of PUHY-M300YNW-A1(-BS)

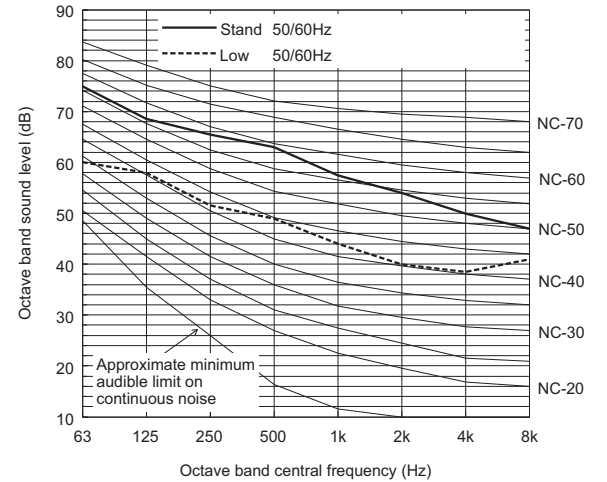

		63	125	250	500	1k	2k	4k	8k	dB(A)
Standard	50/60Hz	75.0	68.5	65.5	63.0	57.5	54.0	50.0	47.0	64.5
Low noise mode	50/60Hz	60.0	58.0	51.5	49.0	44.0	40.0	38.5	41.0	51.0

When Low noise mode is set, the A/C system's capacity is limited. The system could return to normal operation from Low noise mode automatically in the case that the operation condition is severe.

Sound level of PUHY-M200YNW-A1(-BS)

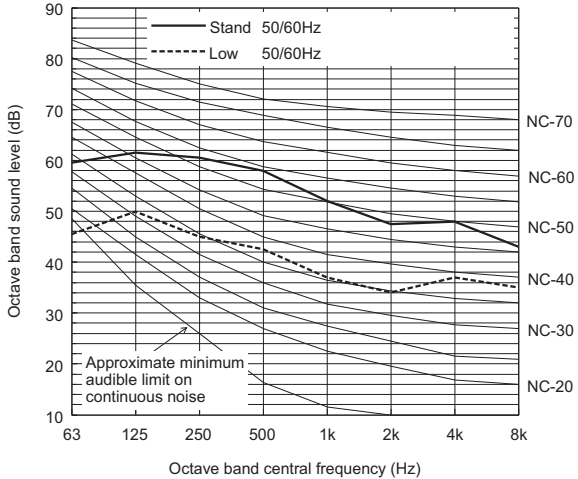

		63	125	250	500	1k	2k	4k	8k	dB(A)
Standard	50/60Hz	59.5	61.5	60.5	58.0	52.0	47.5	43.0	59.0	
Low noise mode	50/60Hz	45.5	50.0	45.0	42.5	37.0	34.0	37.0	45.0	

When Low noise mode is set, the A/C system's capacity is limited. The system could return to normal operation from Low noise mode automatically in the case that the operation condition is severe.

Sound level of PUHY-M250YNW-A1(-BS)

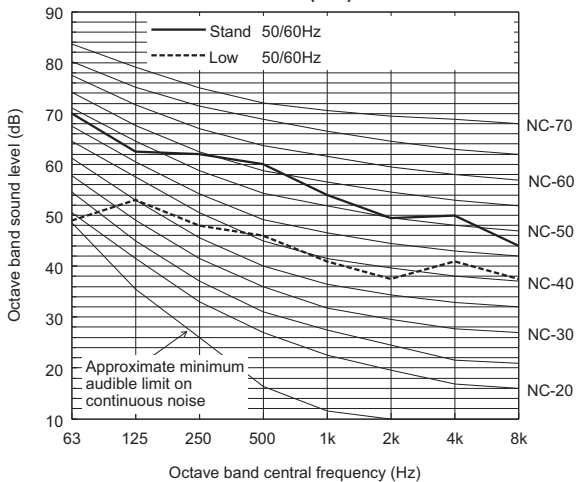

		63	125	250	500	1k	2k	4k	8k	dB(A)
Standard	50/60Hz	70.0	62.5	62.0	60.0	54.0	49.5	50.0	44.0	61.0
Low noise mode	50/60Hz	49.0	53.0	48.0	46.0	41.0	37.5	41.0	37.5	48.5

When Low noise mode is set, the A/C system's capacity is limited. The system could return to normal operation from Low noise mode automatically in the case that the operation condition is severe.

- Depending on the operation conditions, the unit generates noise caused by valve actuation, refrigerant flow, and pressure changes when operating normally. Please consider to avoid location where quietness is required. The sound pressure level measured by the conventional method in JIS for reference purpose.

**Measurement condition**  
**PUHY-EM200, 250, 300YNW-A1(-BS)**

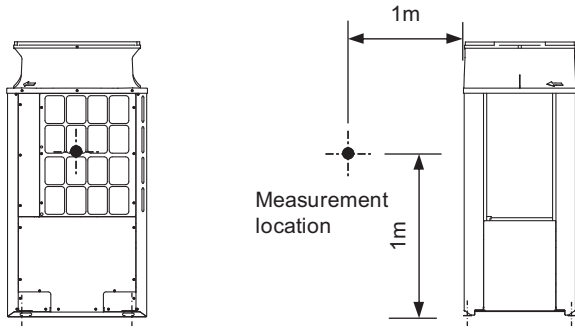

**Sound level of PUHY-EM300YNW-A1(-BS)**

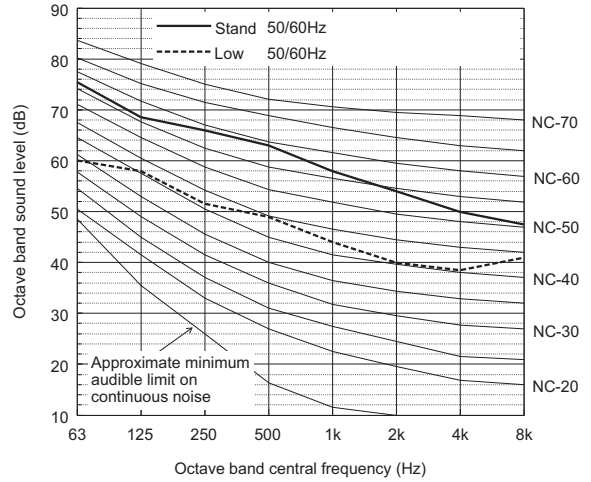

		63	125	250	500	1k	2k	4k	8k	dB(A)
Standard	50/60Hz	75.5	68.5	66.0	63.0	58.0	54.0	50.0	47.5	64.5
Low noise mode	50/60Hz	60.0	58.0	51.5	49.0	44.0	40.0	38.5	41.0	51.0

When Low noise mode is set, the A/C system's capacity is limited. The system could return to normal operation from Low noise mode automatically in the case that the operation condition is severe.

**Sound level of PUHY-EM200YNW-A1(-BS)**

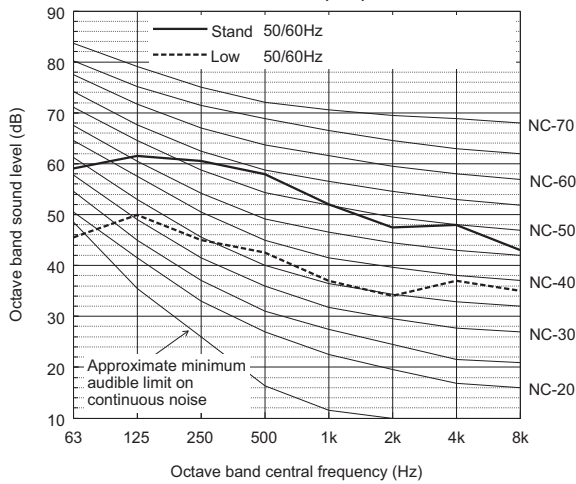

		63	125	250	500	1k	2k	4k	8k	dB(A)
Standard	50/60Hz	59.0	61.5	60.5	58.0	52.0	47.5	48.0	43.0	59.0
Low noise mode	50/60Hz	45.5	50.0	45.0	42.5	37.0	34.0	37.0	35.0	45.0

When Low noise mode is set, the A/C system's capacity is limited. The system could return to normal operation from Low noise mode automatically in the case that the operation condition is severe.

**Sound level of PUHY-EM250YNW-A1(-BS)**

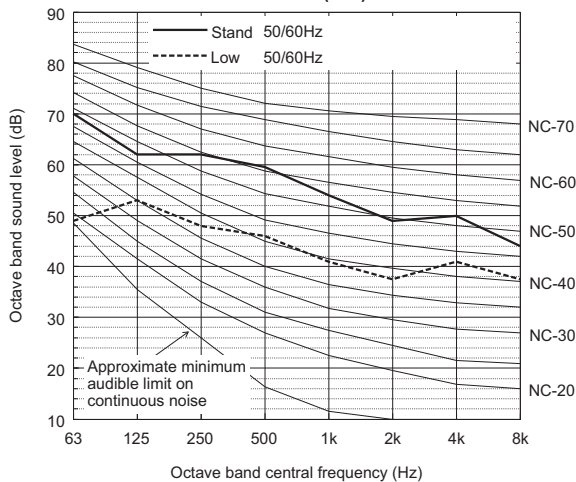

		63	125	250	500	1k	2k	4k	8k	dB(A)
Standard	50/60Hz	70.0	62.0	62.0	59.5	54.0	49.0	50.0	44.0	61.0
Low noise mode	50/60Hz	49.0	53.0	48.0	46.0	41.0	37.5	41.0	37.5	48.5

When Low noise mode is set, the A/C system's capacity is limited. The system could return to normal operation from Low noise mode automatically in the case that the operation condition is severe.

- Depending on the operation conditions, the unit generates noise caused by valve actuation, refrigerant flow, and pressure changes when operating normally. Please consider to avoid location where quietness is required. The sound pressure level measured by the conventional method in JIS for reference purpose.

**[PUHY-M200-300YNW-A1, PUHY-EM200-300YNW-A1]**

## Measurement condition

Measurement frequency: 1 Hz-80 Hz

Measurement point: Ground surface 20 cm away from the unit leg

Installation condition: Direct installation on the concrete floor

Power source: 3-phase 4-wire 380-400-415 V 50/60 Hz

Operation condition: JIS condition (cooling, heating)

Measurement device: Vibration level meter for vibration pollution VM-1220C (JIS-compliant product)

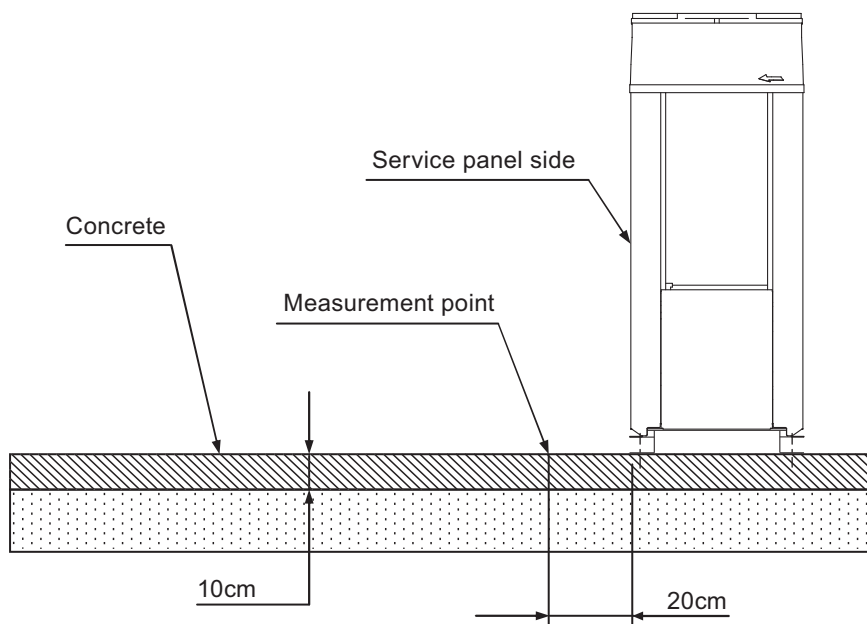

## Vibration level

Model	Vibration level (dB)
PUHY-M200YNW-A1 (-BS)	45
PUHY-M250YNW-A1 (-BS)	46
PUHY-M300YNW-A1 (-BS)	47
PUHY-EM200YNW-A1 (-BS)	45
PUHY-EM250YNW-A1 (-BS)	46
PUHY-EM300YNW-A1 (-BS)	47

\* Vibration level varies depending on the conditions of actual installation site.

• Cooling only

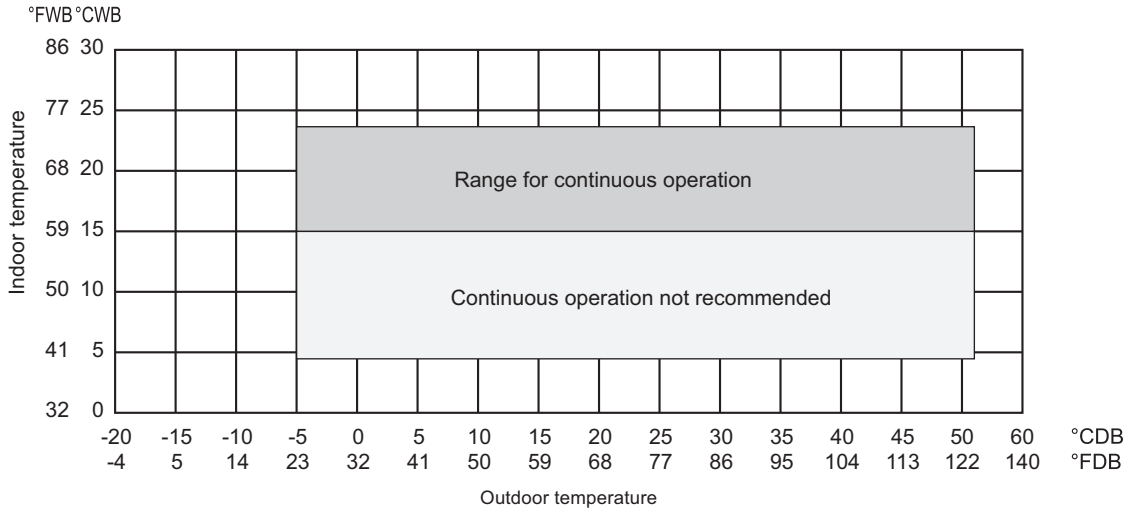

• Heating only

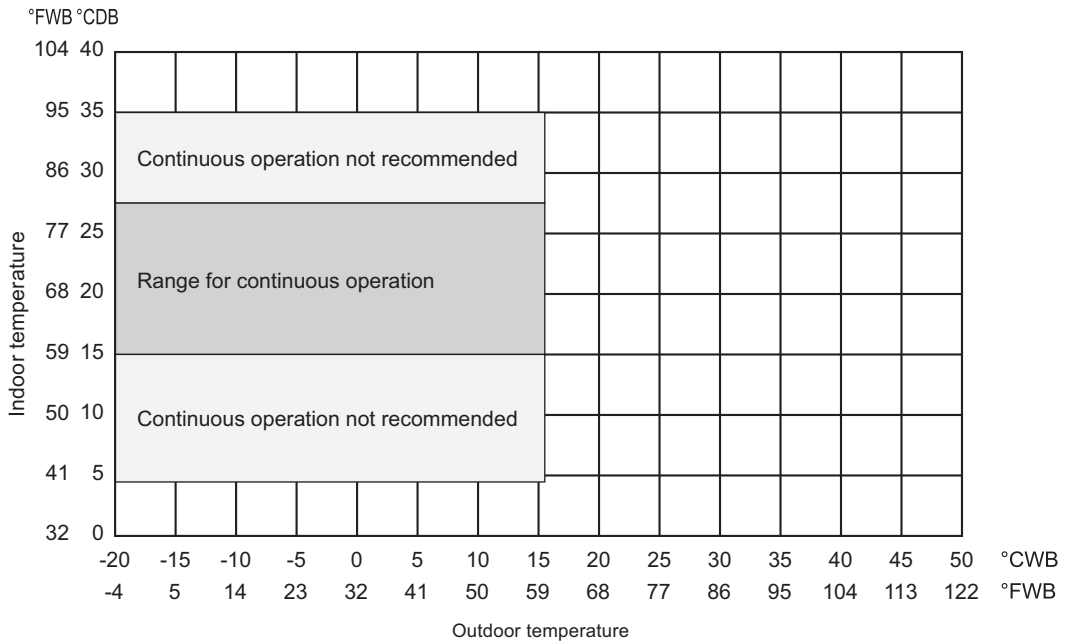

8-1. Selection of Cooling/Heating Units

How to determine the capacity when less than or equal 100% indoor model size units are connected in total:

The purpose of this flow chart is to select the indoor and outdoor units. For other purposes, this flow chart is intended only for reference.

PUHY-M-YNW-A1, EM-YNW-A1

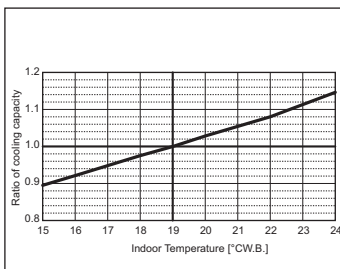
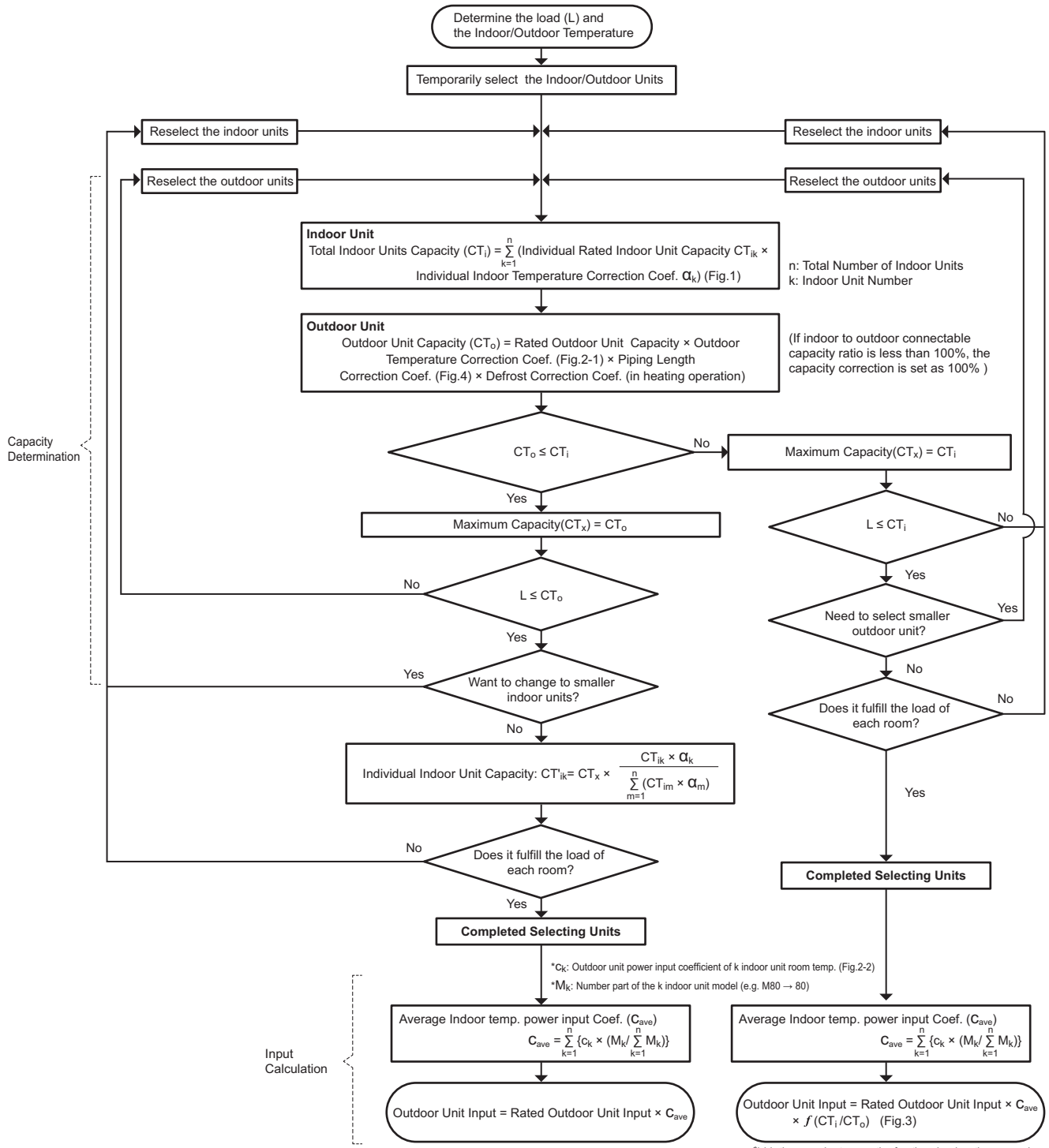

Fig.1 Indoor unit temperature correction

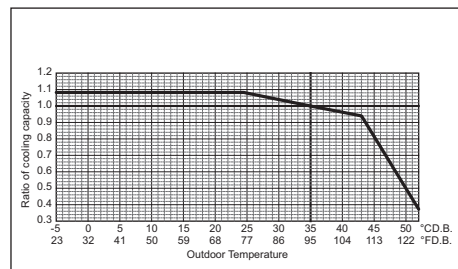

Fig.2-1 Outdoor unit temperature correction (capacity)

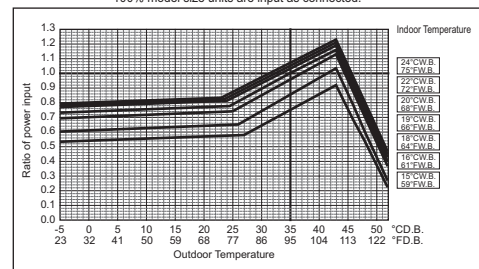

Fig.2-2 Outdoor unit temperature correction (power input)

**How to determine the capacity when greater than 100% indoor model size units are connected in total:**

The purpose of this flow chart is to select the indoor and outdoor units. For other purposes, this flow chart is intended only for reference.

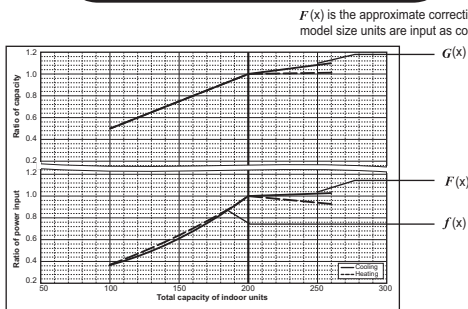
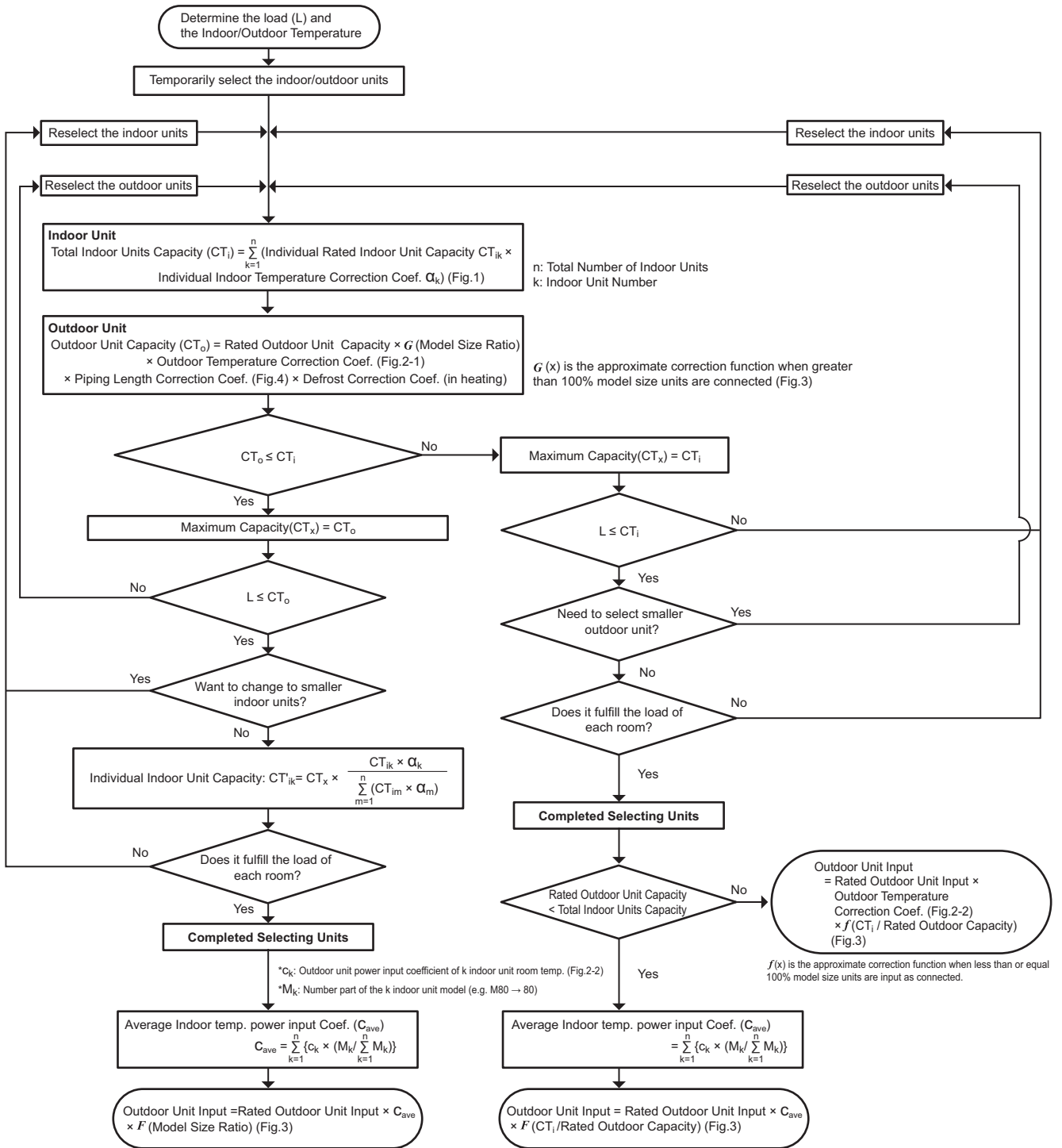

Fig.3 Correction by total indoor

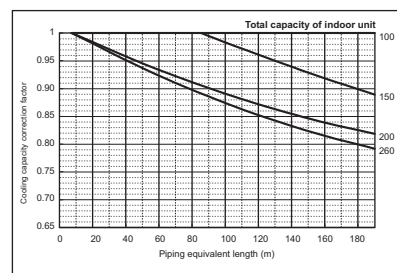

Fig.4 Correction of refrigerant piping length

<Cooling>

Design Condition	
Outdoor Design Dry Bulb Temperature	37 °C
Total Cooling Load	19.0 kW
Room1	
Indoor Design Dry Bulb Temperature	27 °C
Indoor Design Wet Bulb Temperature	20 °C
Cooling Load	9.0 kW
Room2	
Indoor Design Dry Bulb Temperature	24 °C
Indoor Design Wet Bulb Temperature	18 °C
Cooling Load	10.0 kW
<Other>	
Indoor/Outdoor Equivalent Piping Length	50 m

1. Cooling Calculation

(1) Temporary Selection of Indoor Units

Room1	PLFY-M100	11.2 kW (Rated)
Room2	PEFY-M100	11.2 kW (Rated)

(2) Total Indoor Units Capacity

$$M100 + M100 = M200$$

(3) Selection of Outdoor Unit

The M200 outdoor unit is selected as total indoor units capacity is M200

PUHY-EM200	22.4 kW
------------	---------

(4) Total Indoor Units Capacity Correction Calculation

Room1	Indoor Design Wet Bulb Temperature Correction (20°C)	1.03 (Refer to Fig.1)
Room2	Indoor Design Wet Bulb Temperature Correction (18°C)	0.98 (Refer to Fig.1)

Total Indoor Units Capacity (CTi)

$$CTi = \Sigma (\text{Indoor Unit Rating} \times \text{Indoor Design Temperature Correction})$$

$$= 11.2 \times 1.03 + 11.2 \times 0.98$$

$$= 22.5 \text{ kW}$$

(5) Outdoor Unit Correction Calculation

Outdoor Design Dry Bulb Temperature Correction (37°C)	0.99 (Refer to Fig.2)
Piping Length Correction (50 m)	0.95 (Refer to Fig.3)

Total Outdoor Unit Capacity (CTo)

$$CTo = \text{Outdoor Rating} \times \text{Outdoor Design Temperature Correction} \times \text{Piping Length Correction}$$

$$= 22.4 \times 0.99 \times 0.95$$

$$= 21.0 \text{ kW}$$

(6) Determination of Maximum System Capacity (CTx)

Comparison of Capacity between Total Indoor Units Capacity (CTi) and Total Outdoor Unit Capacity (CTo)

$$CTi = 22.5 > CTo = 21.0, \text{ thus, select } CTo.$$

$$CTx = CTo = 21.0 \text{ kW}$$

(7) Comparison with Essential Load

Against the essential load 19.0kW, the maximum system capacity is 21.0kW: Proper outdoor units have been selected.

(8) Calculation of Maximum Indoor Unit Capacity of Each Room

CTx = CTo, thus, calculate by the calculation below

Room1

$$\text{Maximum Capacity} \times \text{Room1 Capacity after the Temperature Correction} / (\text{Room1,2 Total Capacity after the Temperature Correction})$$

$$= 21.0 \times (11.2 \times 1.03) / (11.2 \times 1.03 + 11.2 \times 0.98)$$

$$= 10.8 \text{ kW} \quad \text{OK: fulfills the load 9.0kW}$$

Room2

$$\text{Maximum Capacity} \times \text{Room2 Capacity after the Temperature Correction} / (\text{Room1,2 Total Capacity after the Temperature Correction})$$

$$= 21.0 \times (11.2 \times 0.98) / (11.2 \times 1.03 + 11.2 \times 0.98)$$

$$= 10.2 \text{ kW} \quad \text{OK: fulfills the load 10.0kW}$$

Go on to the heating trial calculation since the selected units fulfill the cooling loads of Room 1, 2.

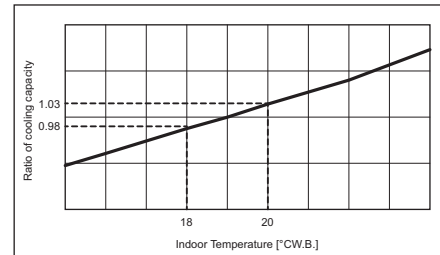

Fig.1 Indoor unit temperature correction

To be used to correct indoor unit only

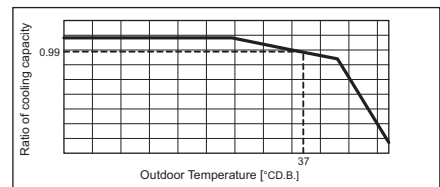

Fig.2 Outdoor unit temperature correction

To be used to correct outdoor unit only

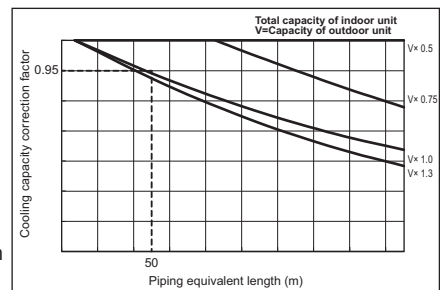

Fig.3 Correction of refrigerant piping length

PUHY-M-YNW-A1, EM-YNW-A1



<Heating>

Design Condition	
Outdoor Design Wet Bulb Temperature	-3 °C
Total Heating Load	18.5 kW
Room1	
Indoor Design Dry Bulb Temperature	25 °C
Heating Load	9.5 kW
Room2	
Indoor Design Dry Bulb Temperature	25 °C
Heating Load	9.0 kW
<Other>	
Indoor/Outdoor Equivalent Piping Length	50 m

2. Heating Calculation

(1) Temporary Selection of Indoor Units

Room1	PLFY-M100	12.5 kW (Rated)
Room2	PEFY-M100	12.5 kW (Rated)

(2) Total Indoor Units Capacity

M100 + M100 = M200

(3) Selection of Outdoor Unit

The M200 outdoor unit is selected as total indoor units capacity is M200

PUHY-EM200 **25.0 kW**

(4) Total Indoor Units Capacity Correction Calculation

Room1	Indoor Design Dry Bulb Temperature Correction (25°C)	0.80 (Refer to Fig.4)
Room2	Indoor Design Dry Bulb Temperature Correction (25°C)	0.80 (Refer to Fig.4)

Total Indoor Units Capacity (CTi)

$$CTi = \sum (\text{Indoor Unit Rating} \times \text{Indoor Design Temperature Correction})$$

$$= 12.5 \times 0.80 + 12.5 \times 0.80$$

$$= 20.0 \text{ kW}$$

(5) Outdoor Unit Correction Calculation

Outdoor Design Wet Bulb Temperature Correction (-3°C)	0.98 (Refer to Fig.5)
Piping Length Correction (60 m)	0.97 (Refer to Fig.6)
Defrost Correction	0.89 (Refer to Tbl.1)

Total Outdoor Unit Capacity (CTo)

$$CTo = \text{Outdoor Unit Rating} \times \text{Outdoor Design Temperature Correction} \times \text{Piping Length Correction} \times \text{Defrost Correction}$$

$$= 25.0 \times 0.98 \times 0.97 \times 0.89$$

$$= 21.1 \text{ kW}$$

(6) Determination of Maximum System Capacity (CTx)

Comparison of Capacity between Total Indoor Units Capacity (CTi) and Total Outdoor Unit Capacity (CTo)

CTi = 20.0 < CTo = 21.1, thus, select CTi.

CTx = CTi = 20.0 kW

(7) Comparison with Essential Load

Against the essential load 18.5kW, the maximum system capacity is 20.0kW: Proper outdoor units have been selected.

(8) Calculation of Maximum Indoor Unit Capacity of Each Room

CTx = CTi, thus, calculate by the calculation below

Room1	Indoor Unit Rating × Indoor Design Temperature Correction	OK: fulfills the load 9.5kW
	= 12.5 × 0.80	
	= 10.0 kW	

Room2	Indoor Unit Rating × Indoor Design Temperature Correction	OK: fulfills the load 9.0kW
	= 12.5 × 0.80	
	= 10.0 kW	

Completed selecting units since the selected units fulfill the heating loads of Room 1, 2.

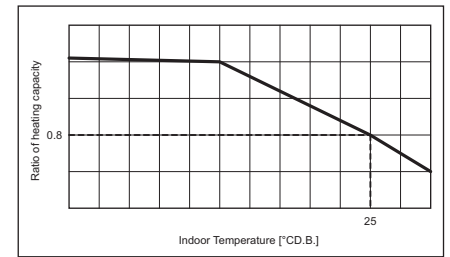

Fig.4 Indoor unit temperature correction  
To be used to correct indoor unit only

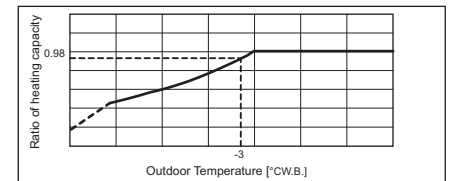

Fig.5 Outdoor unit temperature correction  
To be used to correct outdoor unit only

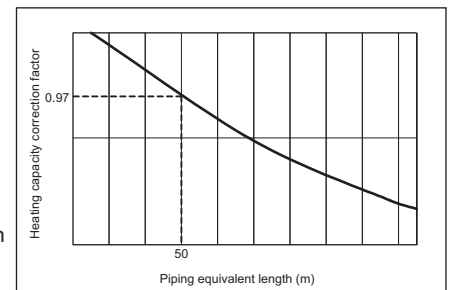

Fig.6 Correction of refrigerant piping length

Tbl.1 Table of correction factor at frost and defrost

Outdoor inlet air temp. °CWB	6	4	2	1	0	-2	-4	-6	-8	-10	-20
Outdoor inlet air temp. °FWB	43	39	36	34	32	28	25	21	18	14	-4
PUHY-M200	1.00	0.95	0.84	0.825	0.83	0.87	0.90	0.95	0.95	0.95	0.95
PUHY-M250	1.00	0.95	0.84	0.825	0.83	0.87	0.90	0.95	0.95	0.95	0.95
PUHY-M300	1.00	0.93	0.82	0.80	0.82	0.86	0.90	0.90	0.95	0.95	0.95

## 3. Power input of outdoor unit

&lt;Cooling&gt;

**(1) Rated power input of outdoor unit** **5.19 kW****(2) Calculation of the average indoor temperature power input coefficient**

Coefficient of the outdoor unit for indoor unit 1 (Outdoor temp. 37 °CD.B., Indoor temp. 20 °CW.B.)

1.07

Coefficient of the outdoor unit for indoor unit 2 (Outdoor temp. 37 °CD.B., Indoor temp. 18 °CW.B.)

1.00

$$\text{Average indoor temp. power input coefficient } (C_{ave}) = \sum_{k=1}^n \{c_k \times (M_k / \sum_{k=1}^n M_k)\}$$

n: Total number of the indoor units

k: Number of the indoor unit

c<sub>k</sub>: Outdoor unit power input coefficient of k indoor unit room temp.M<sub>k</sub>: Number part of the k indoor unit model (e.g. M80 → 80)

$$= 1.07 \times 100 / (100 + 100) + 1 \times 100 / (100 + 100)$$

$$= 1.04$$

**(3) No need to consider Coefficient of the partial load f(CTi/CTo)** -**(4) Outdoor power input (P<sub>lo</sub>)**Maximum System Capacity (CT<sub>x</sub>) = Total Outdoor unit Capacity (CT<sub>o</sub>), so use the following formulaP<sub>lo</sub> = Outdoor unit Cooling Rated Power Input × Correction Coefficient of Indoor temperature

$$= 5.19 \times 1.04$$

$$= 5.4 \text{ kW}$$

&lt;Heating&gt;

**(1) Rated power input of outdoor unit** **5.73 kW****(2) Calculation of the average indoor temperature power input coefficient**Coefficient of the outdoor unit for indoor unit 1 (Outdoor temp. -3 °CW.B., Indoor temp. 25 °CD.B.)  
1.08Coefficient of the outdoor unit for indoor unit 2 (Outdoor temp. -3 °CW.B., Indoor temp. 25 °CD.B.)  
1.08

$$\text{Average indoor temp. power input coefficient } (C_{ave}) = \sum_{k=1}^n \{c_k \times (M_k / \sum_{k=1}^n M_k)\}$$

n: Total number of the indoor units

k: Number of the indoor unit

c<sub>k</sub>: Outdoor unit power input coefficient of k indoor unit room temp.M<sub>k</sub>: Number part of the k indoor unit model (e.g. M80 → 80)

$$= 1.08 \times 100 / (100 + 100) + 1.08 \times 100 / (100 + 100)$$

$$= 1.08$$

**(3) Coefficient of the partial load  $f$  (CTi/CTo)** **0.91****(4) Outdoor power input (P<sub>lo</sub>)**Maximum System Capacity (CT<sub>x</sub>) = Total Indoor unit Capacity (CT<sub>i</sub>), so use the following formula

$$P_{lo} = \text{Outdoor unit Heating Rated Power Input} \times \text{Correction Coefficient of Indoor temperature} \times f(CT_i/CT_o)$$

$$= 5.73 \times 1.08 \times 0.91$$

$$= 5.65 \text{ kW}$$

8-2. Correction by temperature

CITY MULTI could have varied capacity at different designing temperature. Using the nominal cooling/heating capacity value and the ratio below, the capacity can be observed at various temperature.

PUHY-M-YNW-A1, EM-YNW-A1

PUHY-		M200YNW-A1	M250YNW-A1
Nominal Cooling Capacity	kW	22.4	28.0
	BTU/h	76,400	95,500
Input	kW	4.72	6.96

PUHY-		EM200YNW-A1	EM250YNW-A1
Nominal Cooling Capacity	kW	22.4	28.0
	BTU/h	76,400	95,500
Input	kW	4.38	6.36

Indoor unit temperature correction

To be used to correct indoor unit capacity only

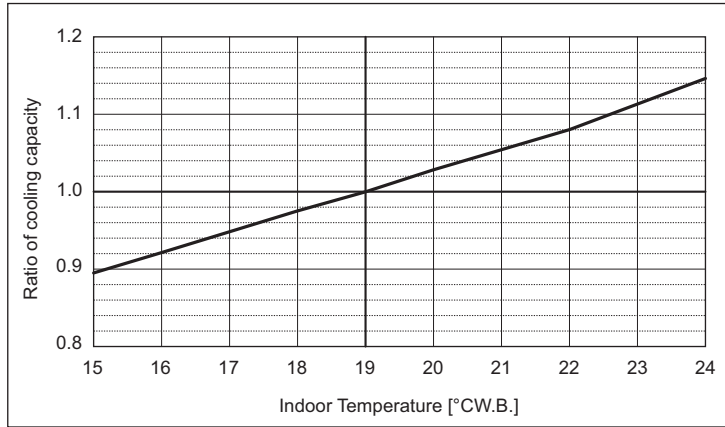

Outdoor unit temperature correction

To be used to correct outdoor unit only

Outdoor unit capacity is NOT affected by the indoor temperature.

Outdoor unit power input is affected by the indoor and outdoor temperatures. Please consult the sales office for details.

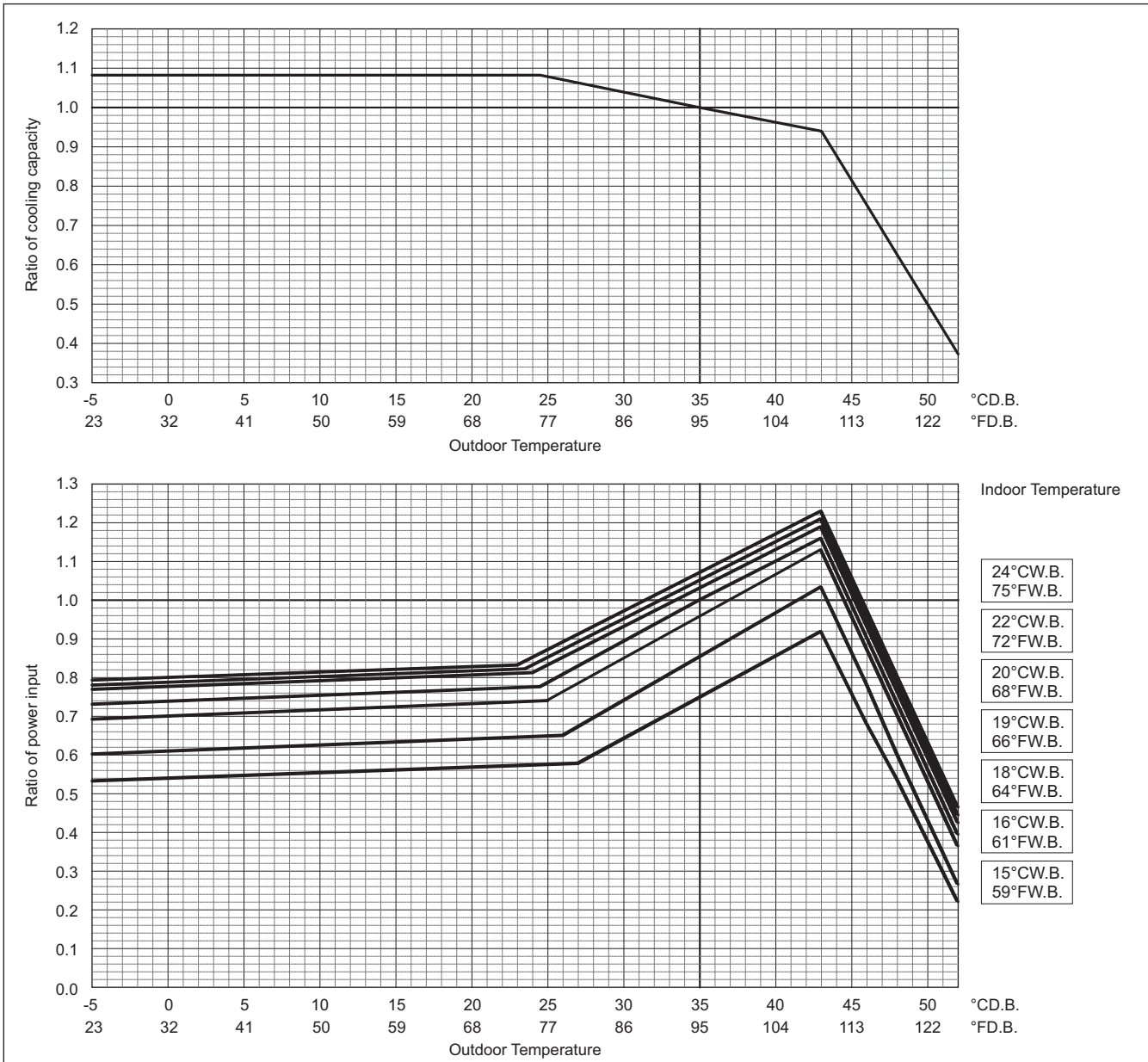

PUHY-		M200YNW-A1	M250YNW-A1
Nominal Heating Capacity	kW	25.0	31.5
	BTU/h	85,300	107,500
Input	kW	5.08	7.14

PUHY-		EM200YNW-A1	EM250YNW-A1
Nominal Heating Capacity	kW	25.0	31.5
	BTU/h	85,300	107,500
Input	kW	4.94	6.92

**Indoor unit temperature correction**  
To be used to correct indoor unit capacity only

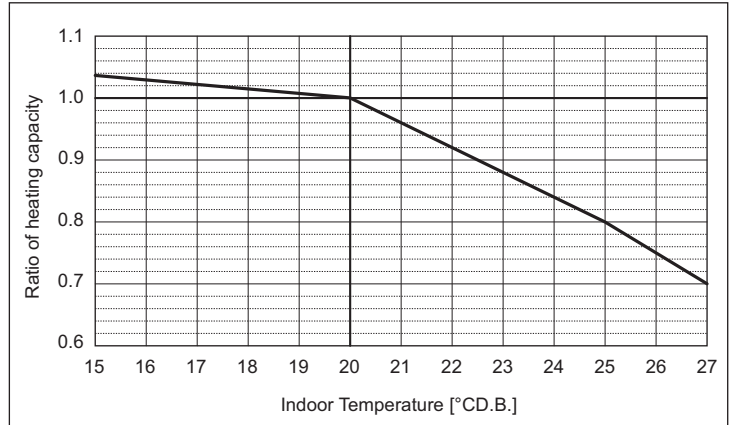

**Outdoor unit temperature correction**

To be used to correct outdoor unit only

Outdoor unit capacity is NOT affected by the indoor temperature.

Outdoor unit power input is affected by the indoor and outdoor temperatures. Please consult the sales office for details.

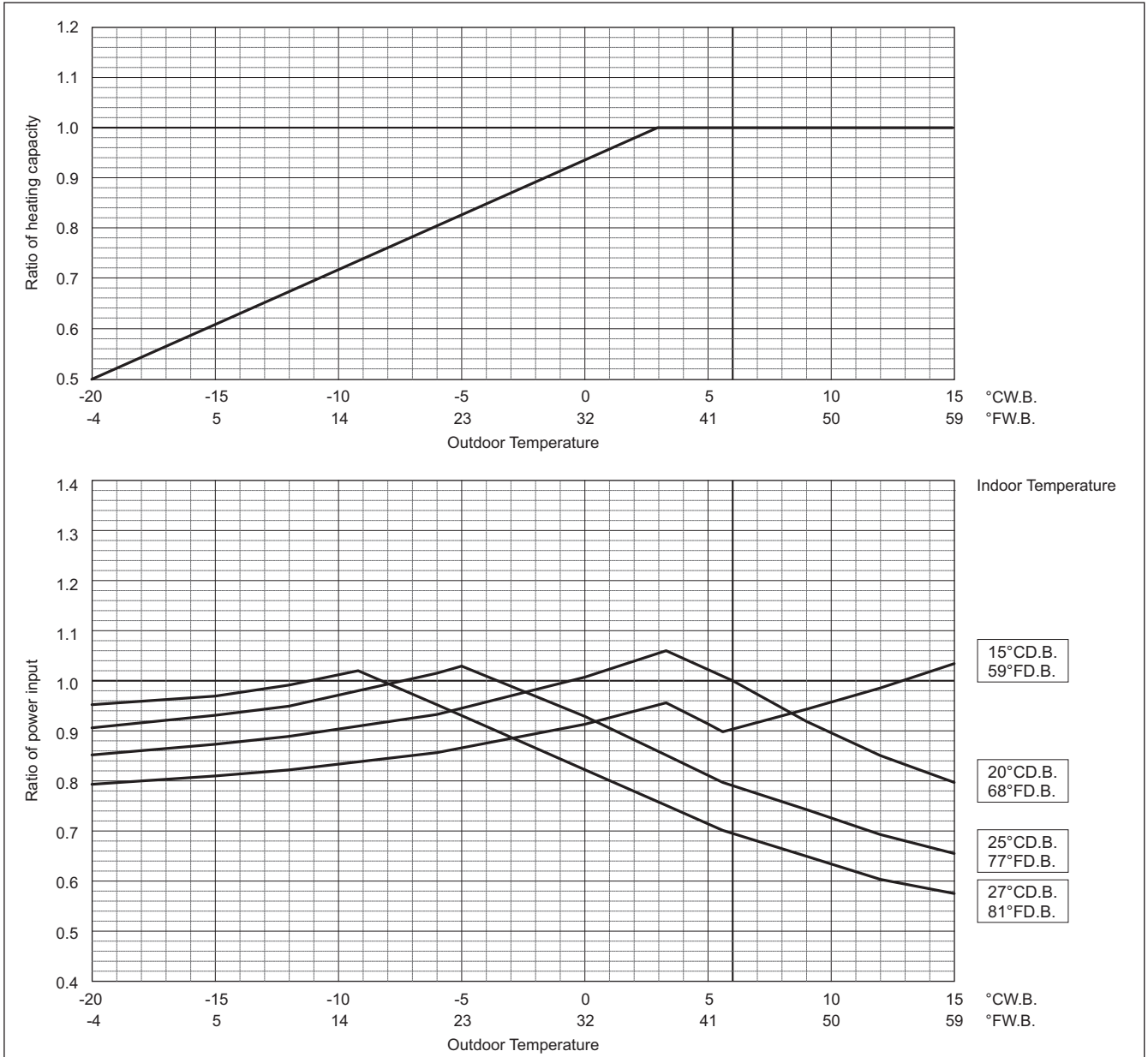

PUHY-M-YNW-A1, EM-YNW-A1

PUHY-M-YNW-A1, EM-YNW-A1

PUHY-		M300YNW-A1
Nominal Cooling Capacity	kW	33.5
	BTU/h	114,300
Input	kW	8.54

PUHY-		EM300YNW-A1
Nominal Cooling Capacity	kW	33.5
	BTU/h	114,300
Input	kW	7.44

**Indoor unit temperature correction**  
To be used to correct indoor unit capacity only

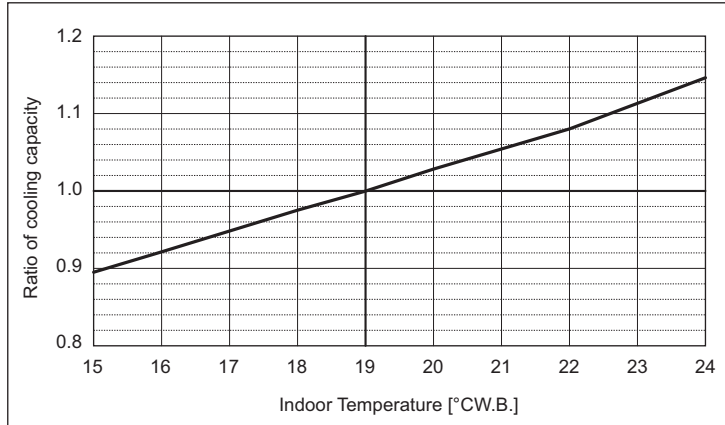

**Outdoor unit temperature correction**

To be used to correct outdoor unit only

Outdoor unit capacity is NOT affected by the indoor temperature.

Outdoor unit power input is affected by the indoor and outdoor temperatures. Please consult the sales office for details.

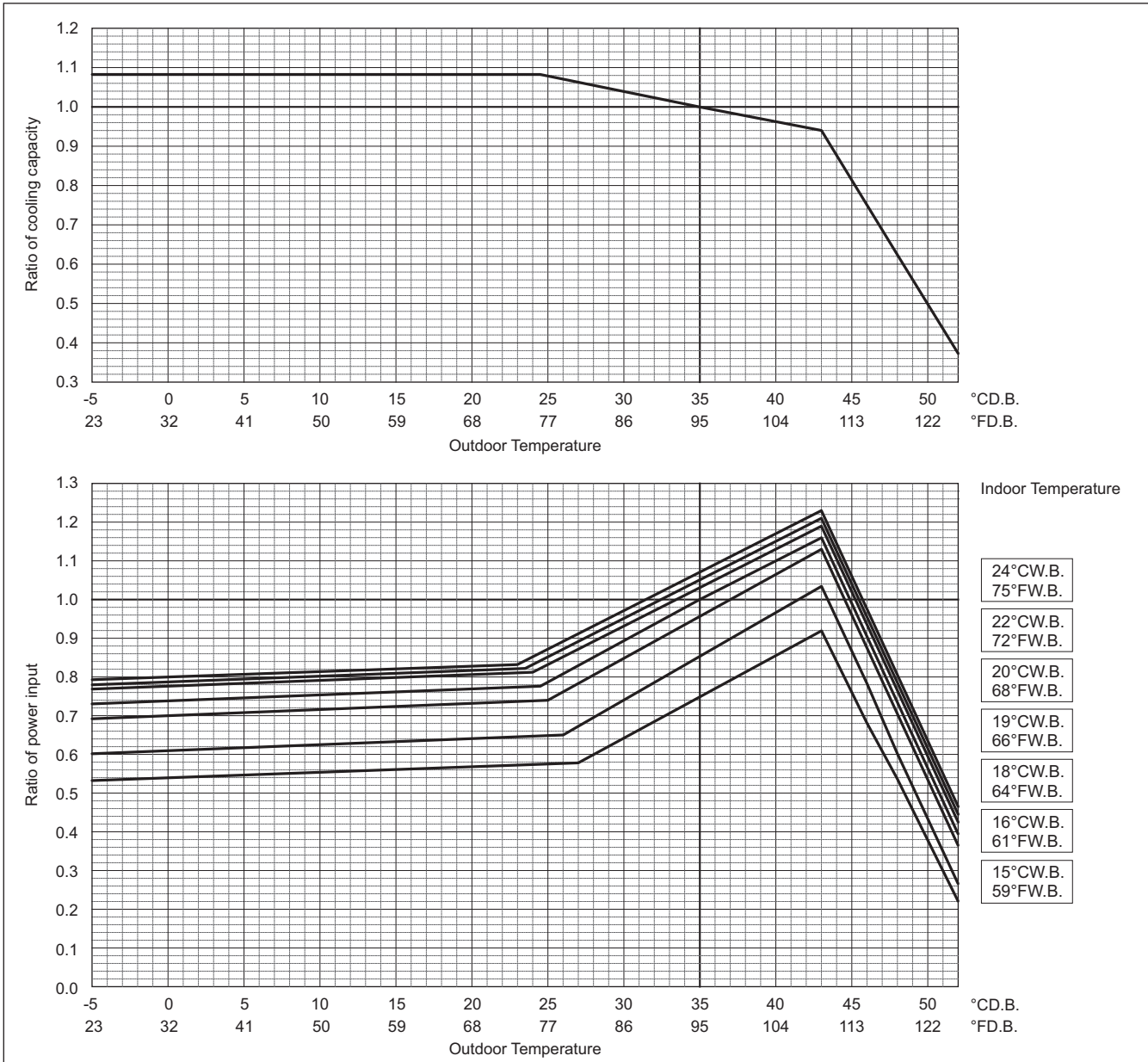

<b>PUHY-</b>		<b>M300YNW-A1</b>
Nominal Heating Capacity	kW	37.5
	BTU/h	128,000
Input	kW	8.33
<b>PUHY-</b>		<b>EM300YNW-A1</b>
Nominal Heating Capacity	kW	37.5
	BTU/h	128,000
Input	kW	7.94

**Indoor unit temperature correction**  
To be used to correct indoor unit capacity only

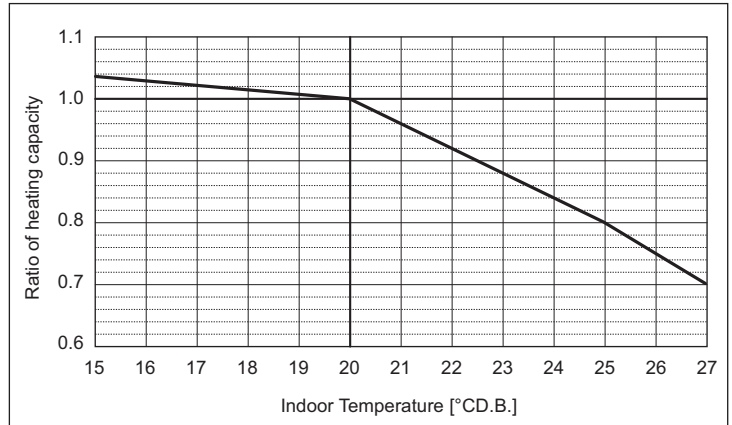

**Outdoor unit temperature correction**

To be used to correct outdoor unit only  
Outdoor unit capacity is NOT affected by the indoor temperature.  
Outdoor unit power input is affected by the indoor and outdoor temperatures. Please consult the sales office for details.

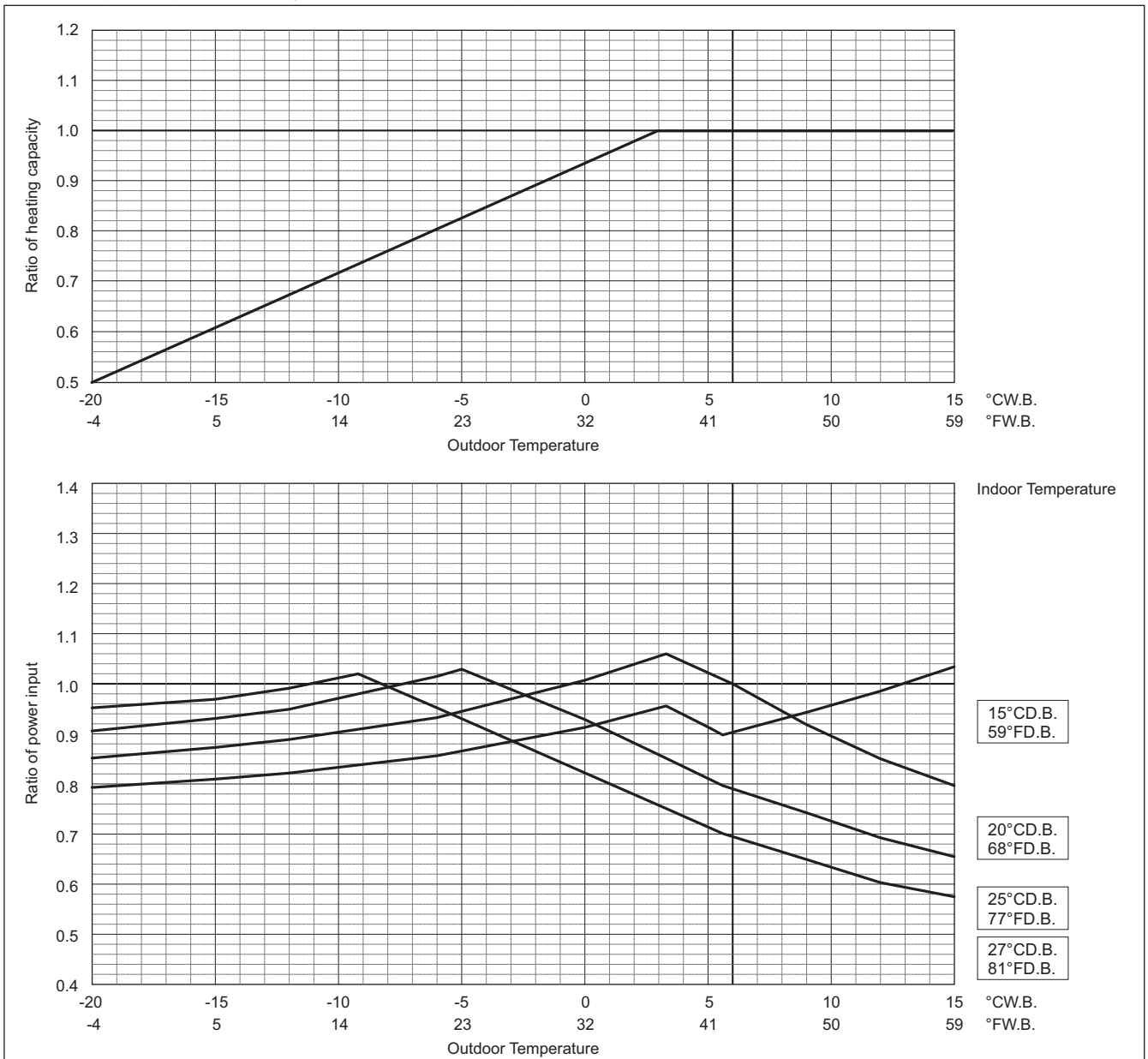

PUHY-M-YNW-A1, EM-YNW-A1

**Correction by temperature (Capacity Priority Mode only for heating)**

CITY MULTI could have various capacities at different designing temperatures. Using the nominal cooling/heating capacity values and the ratios below, the capacity can be found for various temperatures. To select capacity priority mode, DipSW 6-2 must be set to ON.

PUHY-		M200YNW-A1	M250YNW-A1
Nominal Cooling Capacity	kW	22.4	28.0
	BTU/h	76,400	95,500
Input	kW	4.72	6.96

PUHY-		EM200YNW-A1	EM250YNW-A1
Nominal Cooling Capacity	kW	22.4	28.0
	BTU/h	76,400	95,500
Input	kW	4.38	6.36

**Indoor unit temperature correction**

To be used to correct indoor unit capacity only

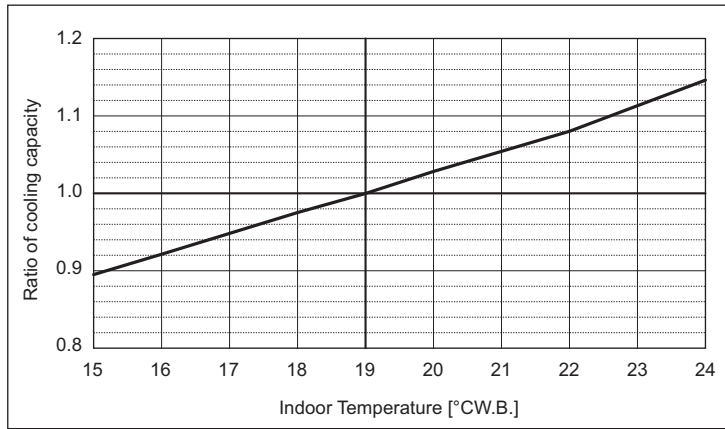

**Outdoor unit temperature correction**

To be used to correct outdoor unit only

Outdoor unit capacity is NOT affected by the indoor temperature.

Outdoor unit power input is affected by the indoor and outdoor temperatures. Please consult the sales office for details.

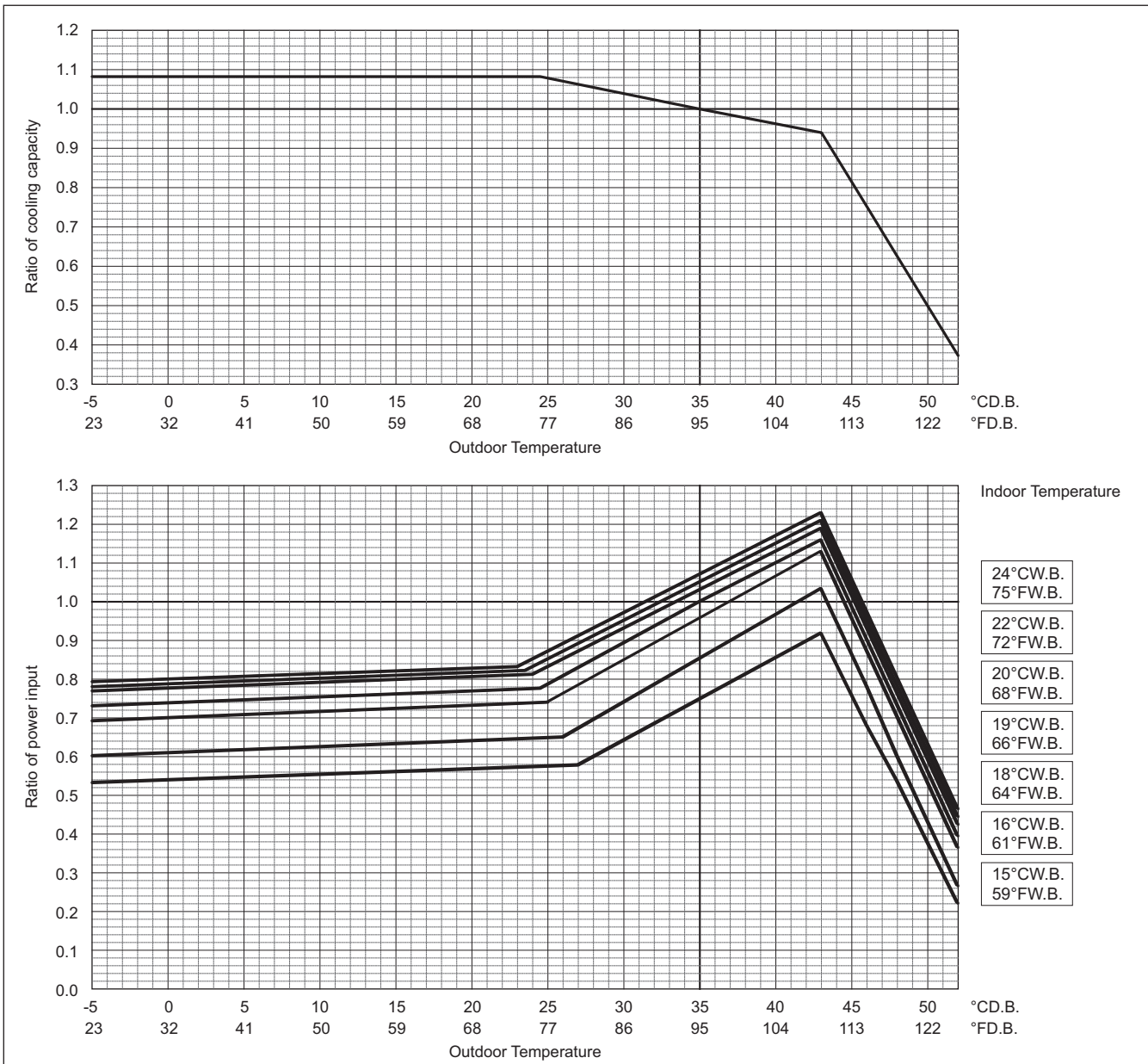

PUHY-M-YNW-A1, EM-YNW-A1



Capacity Priority Mode

PUHY-		M200YNW-A1	M250YNW-A1
Nominal Heating Capacity	kW	25.0	31.5
	BTU/h	85,300	107,500
Input	kW	5.08	7.14

PUHY-		EM200YNW-A1	EM250YNW-A1
Nominal Heating Capacity	kW	25.0	31.5
	BTU/h	85,300	107,500
Input	kW	4.94	6.92

Indoor unit temperature correction

To be used to correct indoor unit capacity only

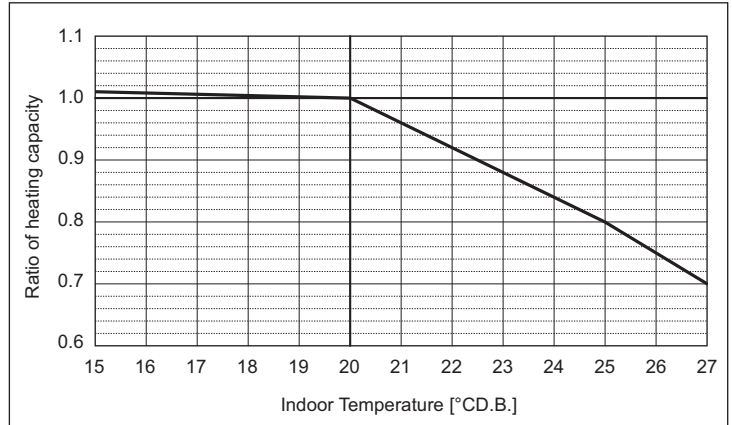

Outdoor unit temperature correction

To be used to correct outdoor unit only

Outdoor unit capacity is NOT affected by the indoor temperature.

Outdoor unit power input is affected by the indoor and outdoor temperatures. Please consult the sales office for details.

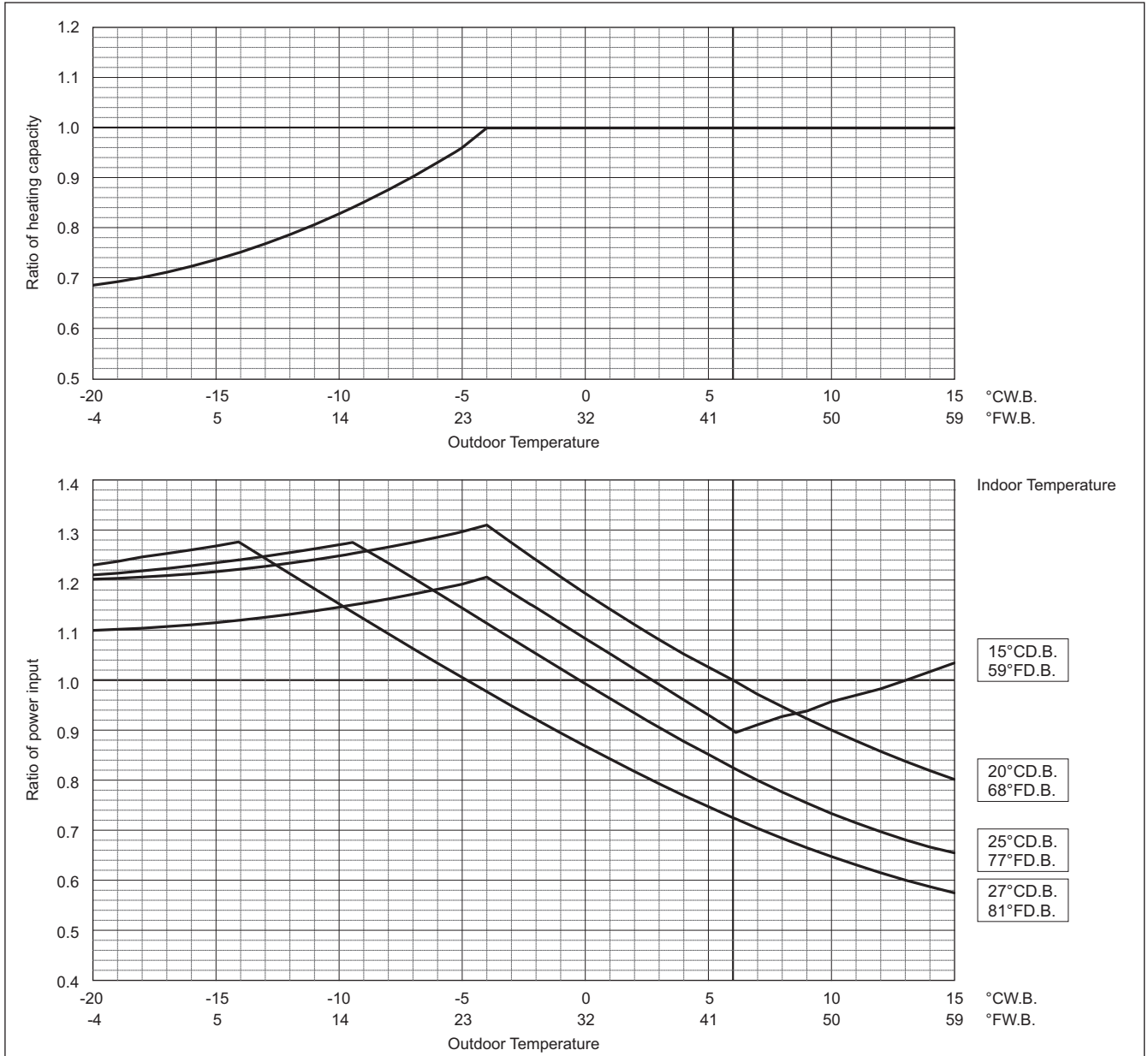

PUHY-M-YNW-A1, EM-YNW-A1

PUHY-M-YNW-A1, EM-YNW-A1

PUHY-		M300YNW-A1
Nominal Cooling Capacity	kW	33.5
	BTU/h	114,300
Input	kW	8.54

PUHY-		EM300YNW-A1
Nominal Cooling Capacity	kW	33.5
	BTU/h	114,300
Input	kW	7.44

**Indoor unit temperature correction**  
To be used to correct indoor unit capacity only

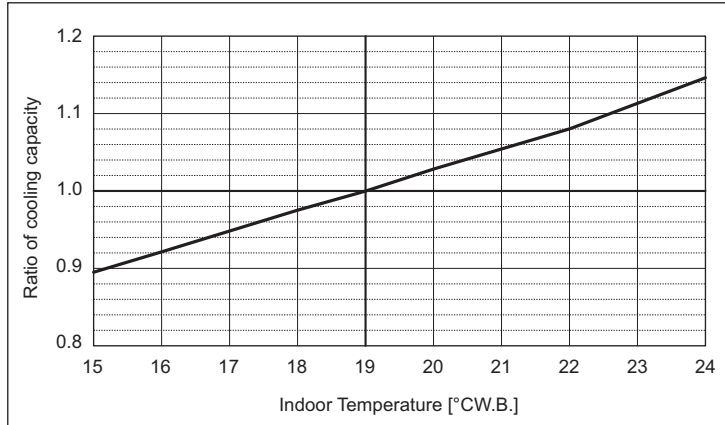

**Outdoor unit temperature correction**

To be used to correct outdoor unit only

Outdoor unit capacity is NOT affected by the indoor temperature.

Outdoor unit power input is affected by the indoor and outdoor temperatures. Please consult the sales office for details.

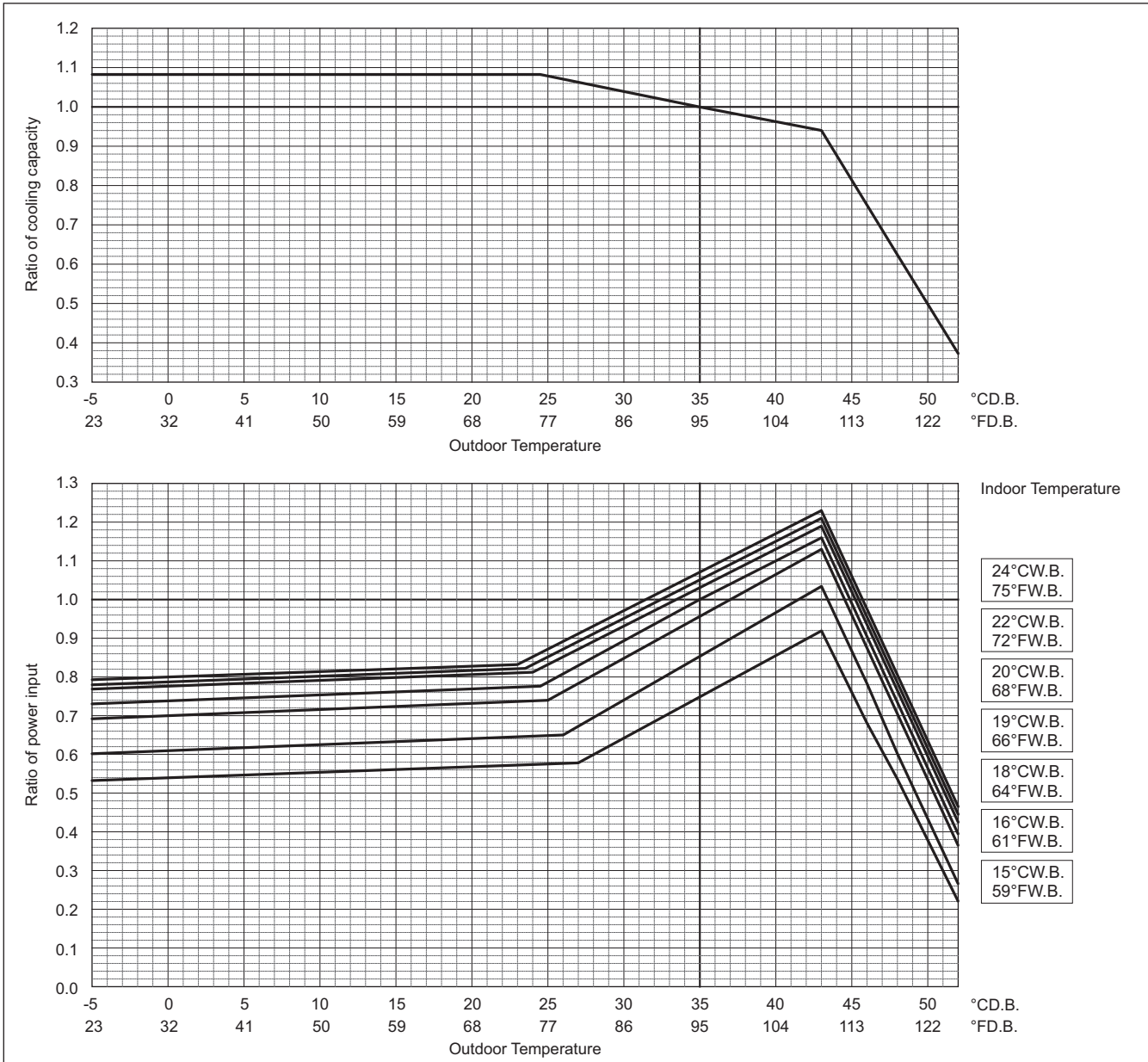

Capacity Priority Mode

PUHY-		M300YNW-A1
Nominal Heating Capacity	kW	37.5
	BTU/h	128,000
Input	kW	8.33

PUHY-		EM300YNW-A1
Nominal Heating Capacity	kW	37.5
	BTU/h	128,000
Input	kW	7.94

Indoor unit temperature correction

To be used to correct indoor unit capacity only

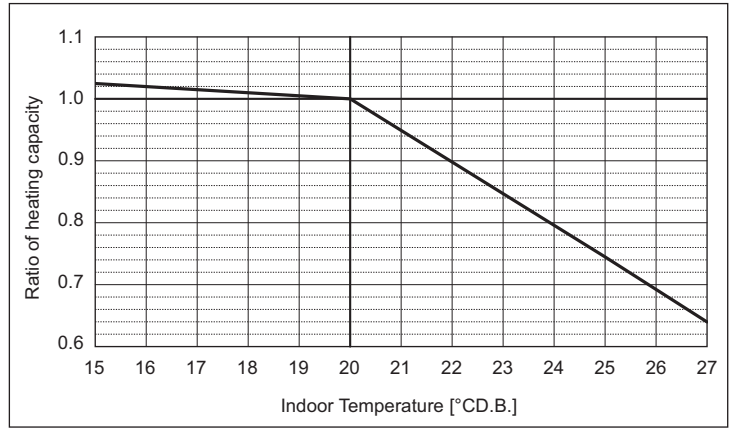

Outdoor unit temperature correction

To be used to correct outdoor unit only

Outdoor unit capacity is NOT affected by the indoor temperature.

Outdoor unit power input is affected by the indoor and outdoor temperatures. Please consult the sales office for details.

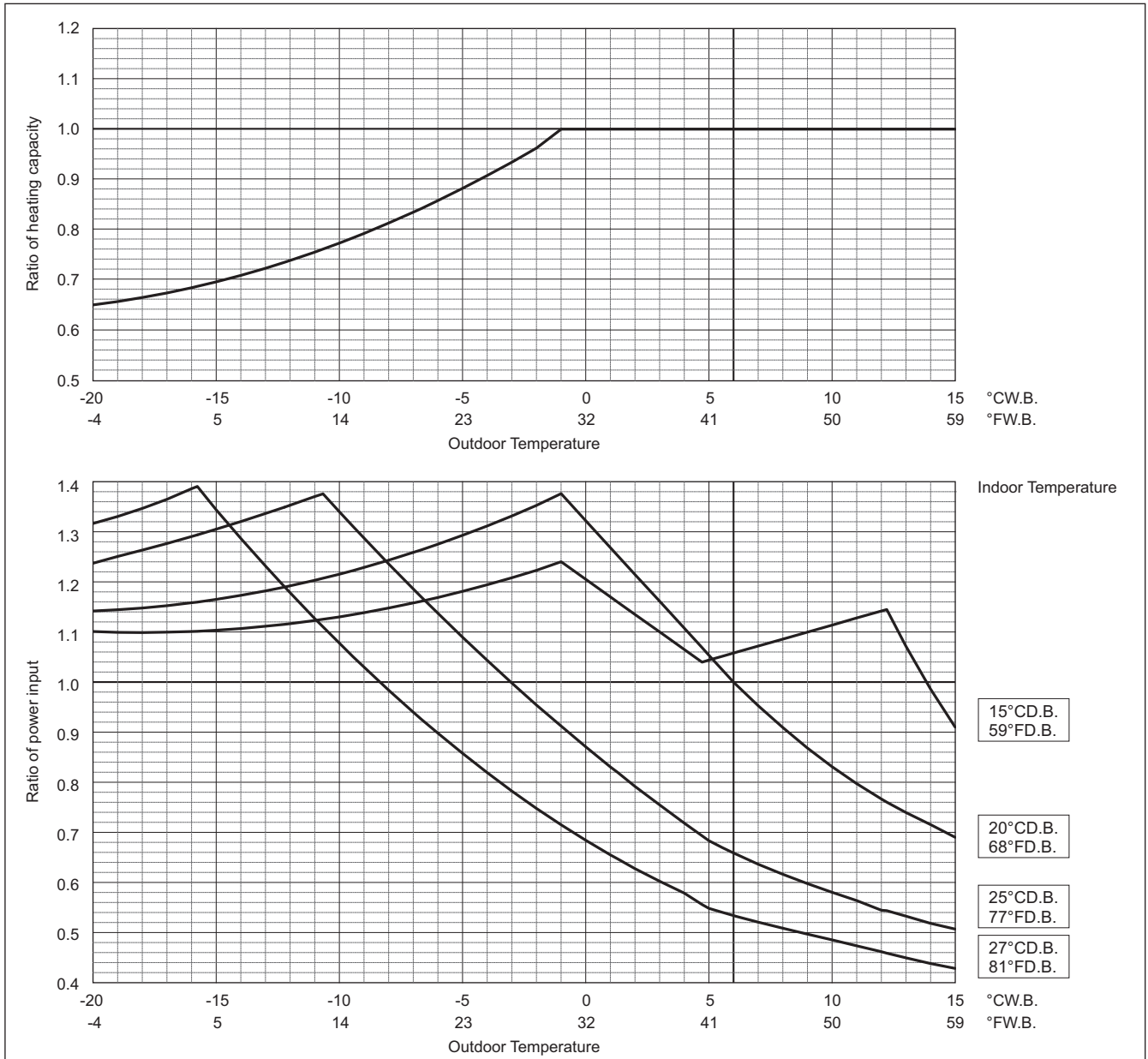

PUHY-M-YNW-A1, EM-YNW-A1

8-3. Correction by total indoor

CITY MULTI system has different capacities and inputs when many combinations of indoor units with different total capacities are connected. Using following tables, the maximum capacity can be found to ensure the system is installed with enough capacity for a particular application.

PUHY-M-YNW-A1, EM-YNW-A1

PUHY-M200YNW-A1		
Cooling Capacity	kW	22.4
	BTU/h	76,400
Input	kW	4.72

PUHY-M200YNW-A1		
Heating Capacity	kW	25.0
	BTU/h	85,300
Input	kW	5.08

PUHY-EM200YNW-A1		
Cooling Capacity	kW	22.4
	BTU/h	76,400
Input	kW	4.38

PUHY-EM200YNW-A1		
Heating Capacity	kW	25.0
	BTU/h	85,300
Input	kW	4.94

PUHY-M250YNW-A1		
Cooling Capacity	kW	28.0
	BTU/h	95,500
Input	kW	6.96

PUHY-M250YNW-A1		
Heating Capacity	kW	31.5
	BTU/h	107,500
Input	kW	7.14

PUHY-EM250YNW-A1		
Cooling Capacity	kW	28.0
	BTU/h	95,500
Input	kW	6.36

PUHY-EM250YNW-A1		
Heating Capacity	kW	31.5
	BTU/h	107,500
Input	kW	6.92

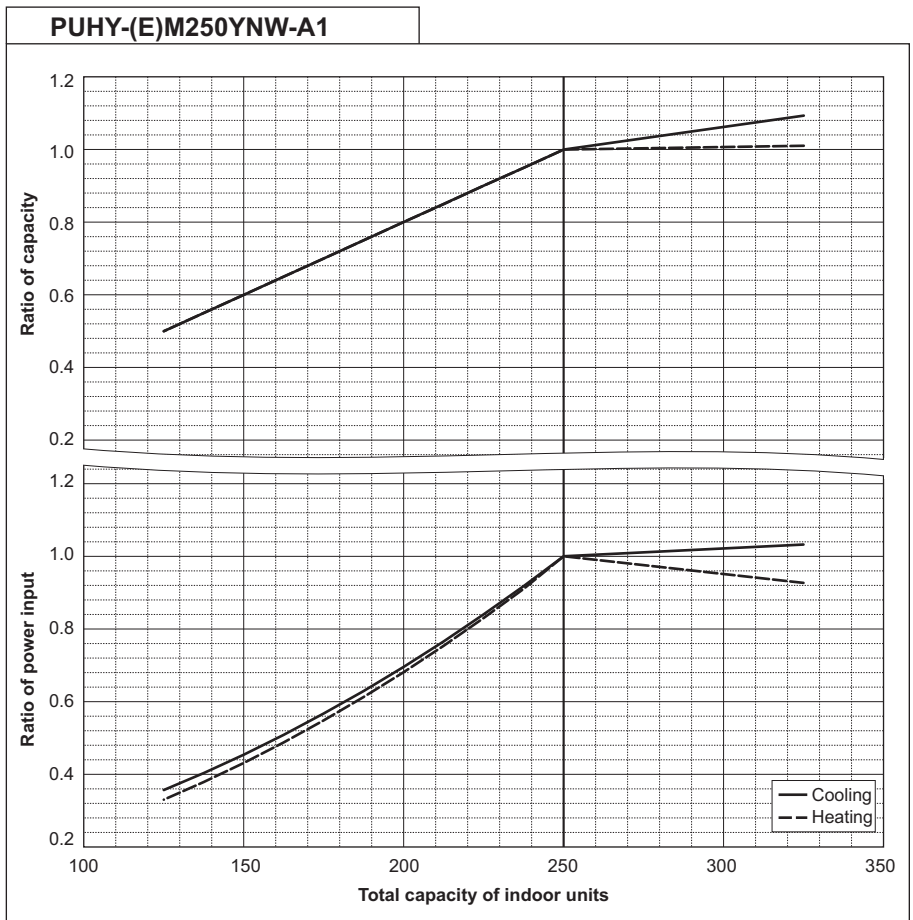
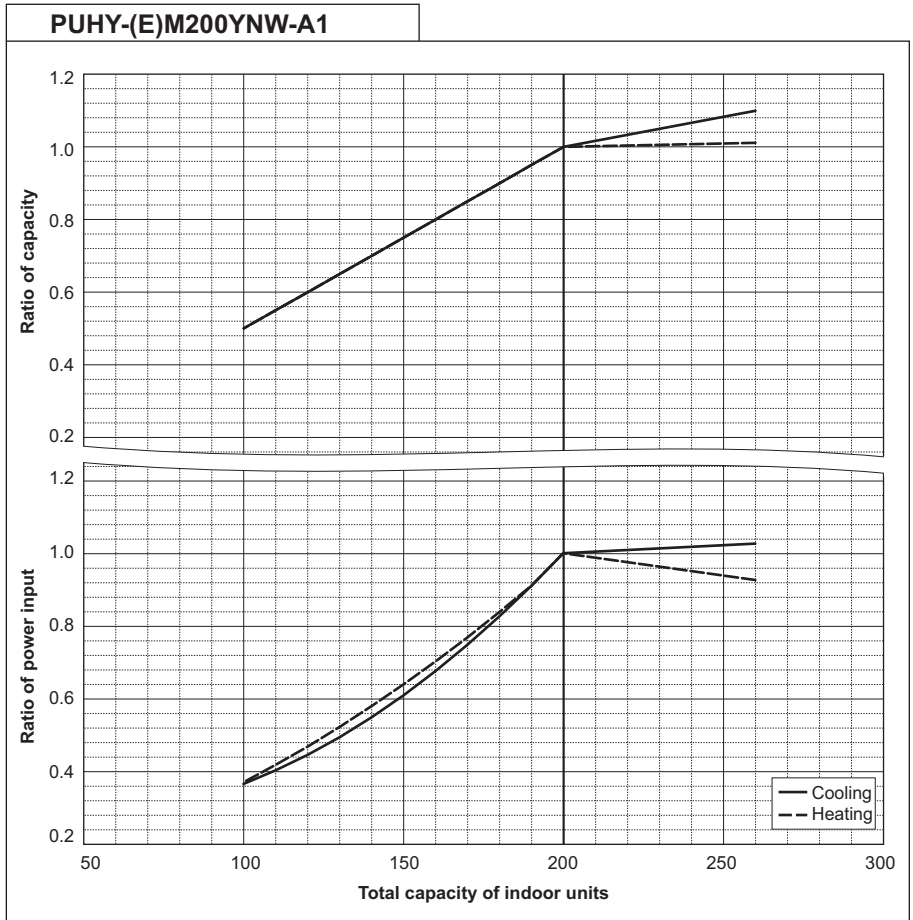

PUHY-M300YNW-A1		
Cooling Capacity	kW	33.5
	BTU/h	114,300
Input	kW	8.54

PUHY-M300YNW-A1		
Heating Capacity	kW	37.5
	BTU/h	128,000
Input	kW	8.33

PUHY-EM300YNW-A1		
Cooling Capacity	kW	33.5
	BTU/h	114,300
Input	kW	7.44

PUHY-EM300YNW-A1		
Heating Capacity	kW	37.5
	BTU/h	128,000
Input	kW	7.94

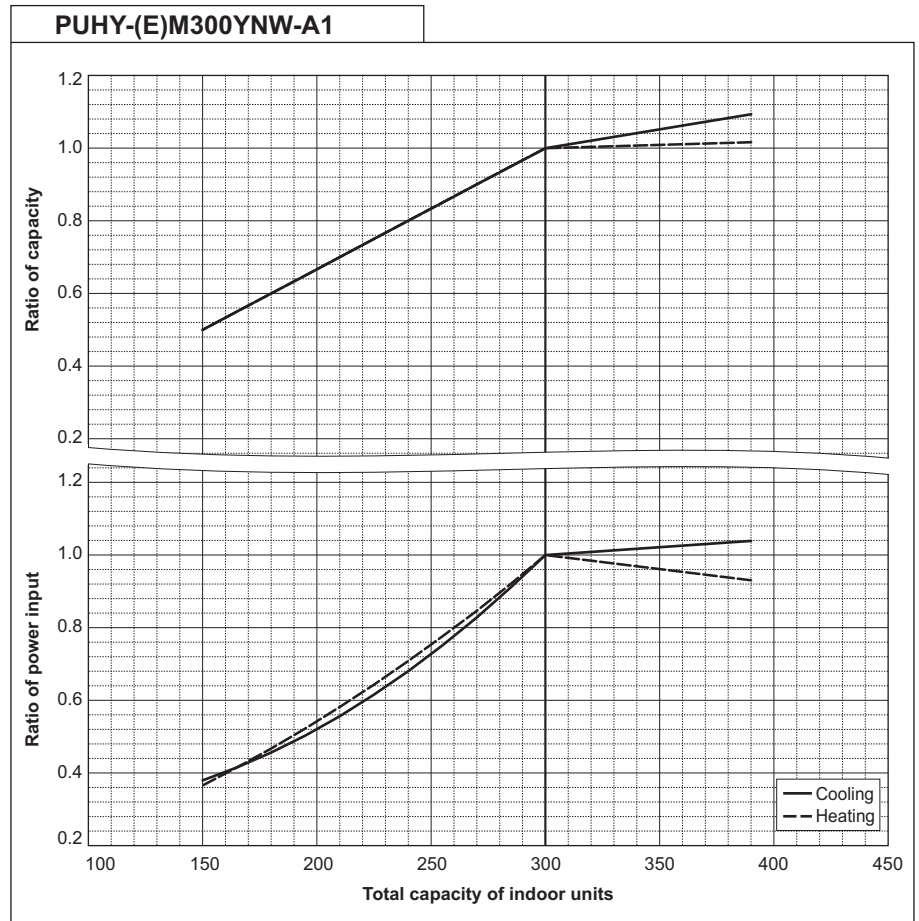

PUHY-M-YNW-A1, EM-YNW-A1

### 8-4. Correction by refrigerant piping length

CITY MULTI system can extend the piping flexibly within its limitation for the actual situation. However, a decrease of cooling/heating capacity could happen correspondently. Using following correction factor according to the equivalent length of the piping shown at 8-4-1 and 8-4-2, the capacity can be observed. 8-4-3 shows how to obtain the equivalent length of piping.

#### 8-4-1. Cooling capacity correction

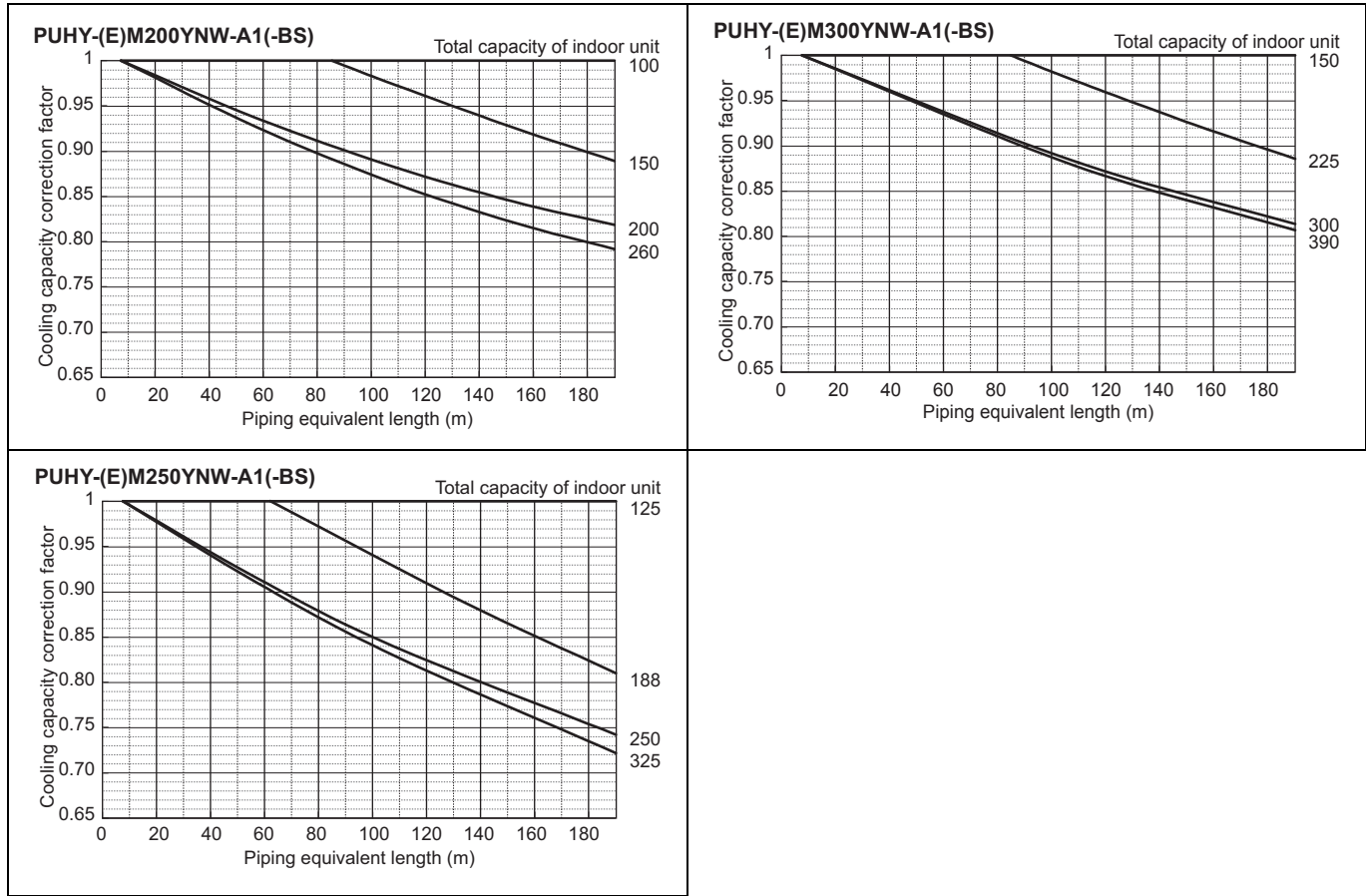

#### 8-4-2. Heating capacity correction

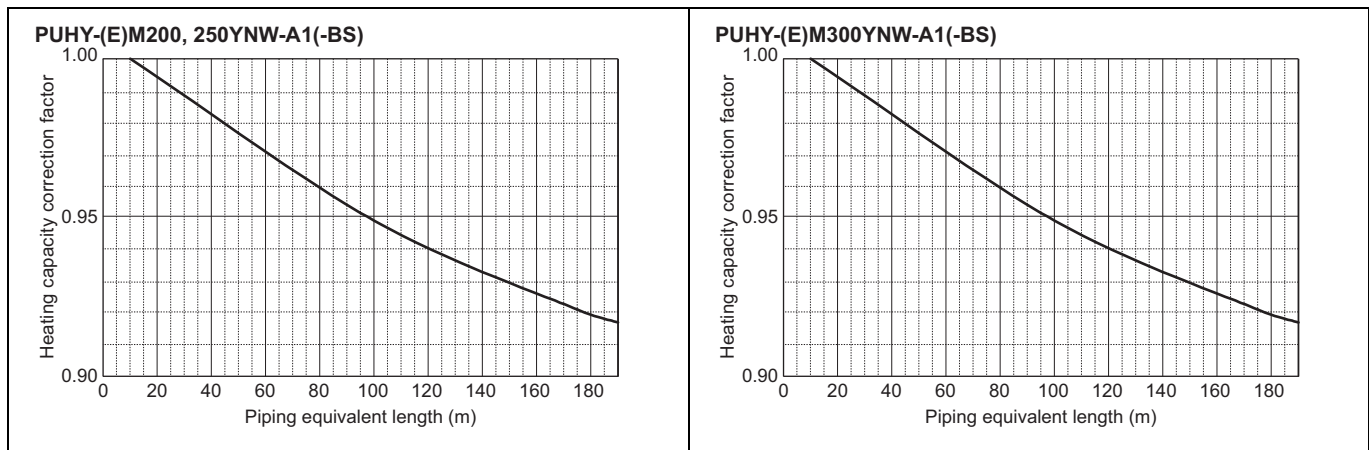

#### 8-4-3. How to obtain the equivalent piping length

- 1. PUHY-(E)M200YNW-A1(-BS)**  
Equivalent length = (Actual piping length to the farthest indoor unit) + (0.42 × number of bends in the piping) [m]
- 2. PUHY-(E)M250YNW-A1(-BS)**  
Equivalent length = (Actual piping length to the farthest indoor unit) + (0.42 × number of bends in the piping) [m]
- 3. PUHY-(E)M300YNW-A1(-BS)**  
Equivalent length = (Actual piping length to the farthest indoor unit) + (0.42 × number of bends in the piping) [m]

**8-5. Correction at frost and defrost**

Due to frost at the outdoor heat exchanger and the automatic defrost operation, the heating capacity of the outdoor unit can be calculated by multiplying the correction factor shown in the table below.

Table of correction factor at frost and defrost

Outdoor inlet air temp. °CWB	6	4	2	1	0	-2	-4	-6	-8	-10	-20
Outdoor inlet air temp. °FWB	43	39	36	34	32	28	25	21	18	14	-4
PUHY-(E)M200YNW-A1(-BS)	1.00	0.95	0.84	0.83	0.83	0.87	0.90	0.95	0.95	0.95	0.95
PUHY-(E)M250YNW-A1(-BS)	1.00	0.95	0.84	0.83	0.83	0.87	0.90	0.95	0.95	0.95	0.95
PUHY-(E)M300YNW-A1(-BS)	1.00	0.95	0.84	0.83	0.83	0.87	0.90	0.95	0.95	0.95	0.95

**8-6. Correction at evaporation-temperature (ET) control**

When the target evaporation temperature is changed, the capacity or the power input can be calculated by multiplying the correction factor shown in the table below.

ET *1	°C	6	9	11	14
Correction factor	Capacity	0.90	0.83	0.71	0.55
	Power Input	0.90	0.72	0.54	0.36

\*1 The evaporation temperature in operation may be different from the preset target evaporation temperature because it depends on such factors as the unit protection control.

The capacity and power input could also fluctuate.

\*2 Use the table above which indicates the unit properties as a reference

9-1. JOINT

CITY MULTI units can be easily connected by using Joint sets and Header sets provided by Mitsubishi Electric. Refer to section "Piping Design" or the Installation Manual that comes with the Joint set for how to install the Joint set.

PUHY-M-YNW-A1, EM-YNW-A1

CMY-Y102SS-G2

mm

For Gas pipe:

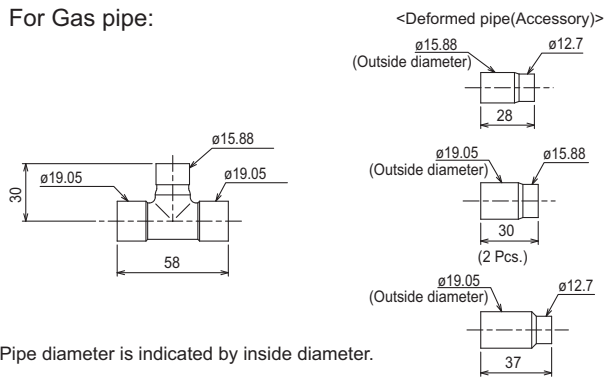

For Liquid pipe:

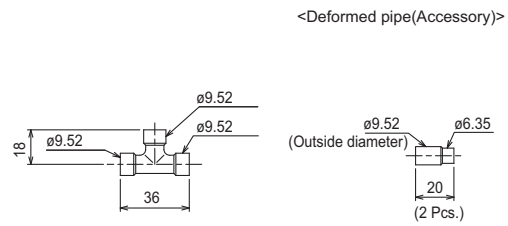

CMY-Y102LS-G2

mm

For Gas pipe:

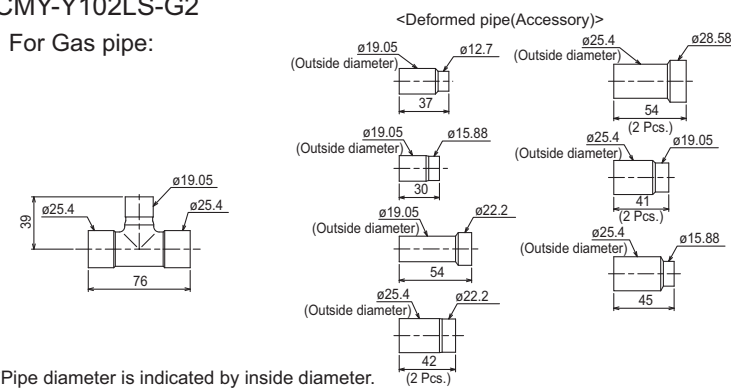

For Liquid pipe:

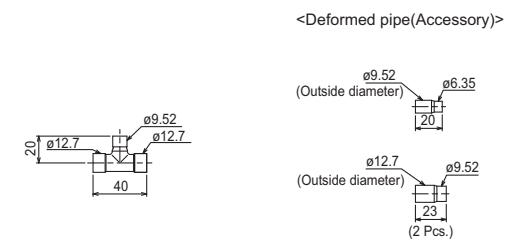



9-2. HEADER

CITY MULTI units can be easily connected by using Joint sets and Header sets provided by Mitsubishi Electric. Refer to section "Piping Design" or the Installation Manual that comes with the Header set for how to install the Header set.

**CMY-Y104-G** mm

For Gas pipe:

For Liquid pipe:

NOTE: Besides above mentioned accessories, caps for pipe of  $\phi 6.35$ ,  $\phi 9.52$ ,  $\phi 12.7$ ,  $\phi 15.88$  (each diameter 1 piece) are included in the Header set.

**CMY-Y108-G** mm

For Gas pipe:

For Liquid pipe:

NOTE: Besides above mentioned accessories, caps for pipe of  $\phi 6.35$ ,  $\phi 9.52$ ,  $\phi 12.7$ ,  $\phi 15.88$  (each diameter 2 pieces) and 1 cap for pipe of  $\phi 19.05$  are included in the Header set.

**CMY-Y1010-G** mm

For Gas pipe:

For Liquid pipe:

NOTE: Besides above mentioned accessories, caps for pipe of  $\phi 6.35$ ,  $\phi 9.52$ ,  $\phi 12.7$ ,  $\phi 15.88$  (each diameter 2 pieces) and 1 cap for pipe of  $\phi 19.05$  are included in the Header set.

9-3. FIN GUARD

PUHY-M-YNW-A1, EM-YNW-A1

PAC-FG01S-E

For side surfaces of S module (a set of two pieces)

■Left side of the unit

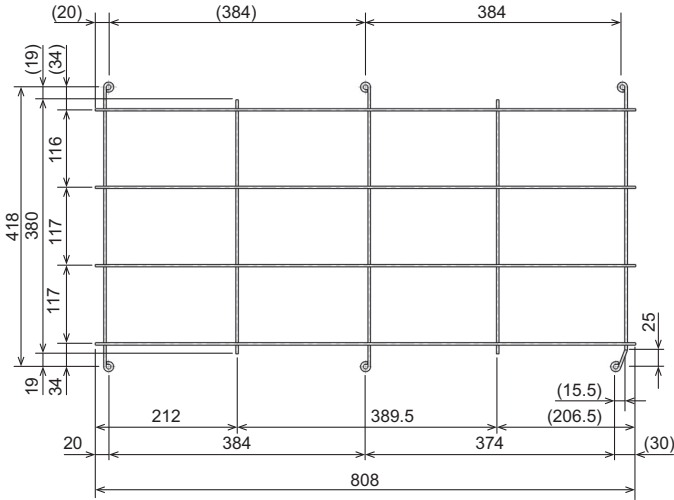

■Right side of the unit

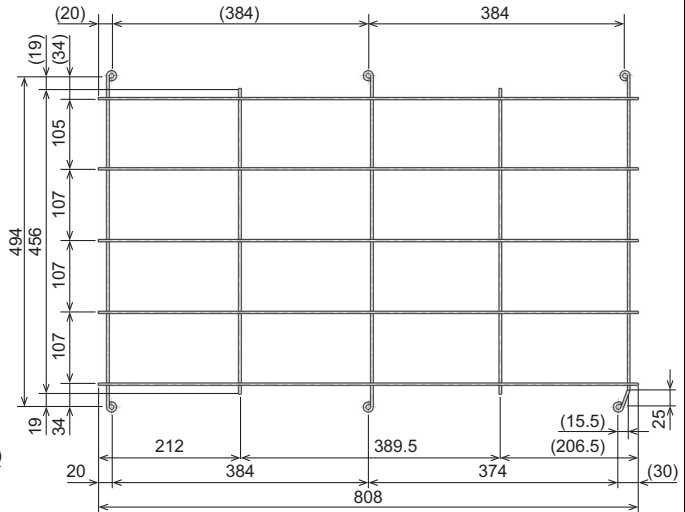

PAC-FG01B-E

For rear surface of S module

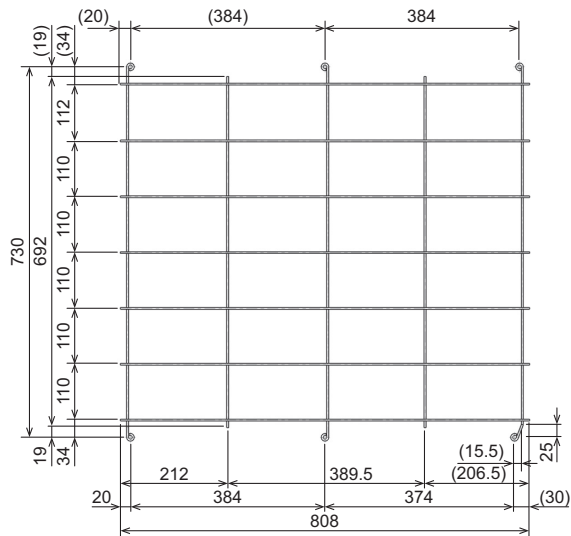

## 10-1. General cautions

- ① Follow ordinance of your governmental organization for technical standard related to electrical equipment, wiring regulations, and guidance of each electric power company.
- ② Wiring for control (hereinafter referred to as transmission cable) shall be (50mm[1-5/8in.] or more) apart from power source wiring so that it is not influenced by electric noise from power source wiring. (Do not insert transmission cable and power source wire in the same conduit.)
- ③ Be sure to provide designated grounding work to outdoor unit.
- ④ Give some allowance to wiring for electrical part box of indoor and outdoor units, because the box is sometimes removed at the time of service work.
- ⑤ Never connect 380~415V(220~240V) power source to terminal block of transmission cable. If connected, electrical parts will be damaged.
- ⑥ Use 2-core shield cable for transmission cable. If transmission cables of different systems are wired with the same multiple-core cable, the resultant poor transmitting and receiving will cause erroneous operations.
- ⑦ When extending the transmission line, make sure to extend the shield cable as well.

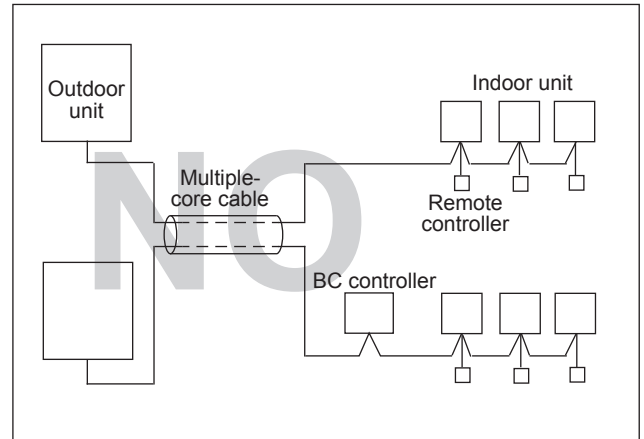
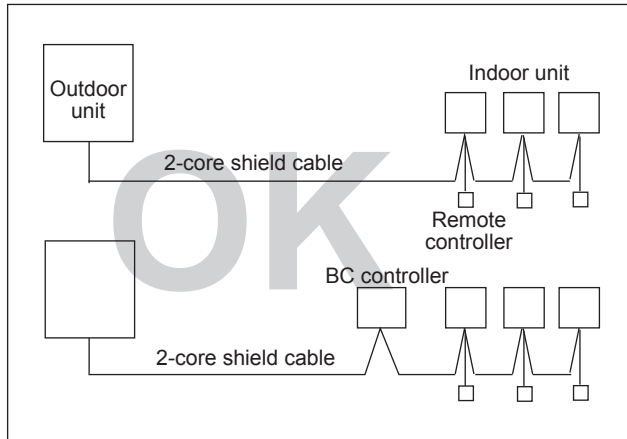

10-2. Power supply for Outdoor unit

10-2-1. Electrical characteristics of the outdoor unit in cooling mode

Symbols: MCA: Max Circuit Amps

RLA: Rated Load Amps SC: Starting Current

PUHY-M-YNW-A1	Unit Combination	Units			Power supply	Compressor		FAN	RLA (A) (50/60Hz)	
		Hz	Volts	Voltage range		MCA (A)	Output (kW)		SC (A)	Output (kW)
PUHY-M200YNW-A1(-BS)	-	50/60	380	Max:456V Min:342V	16.1	4.0	8	0.92	9.3/8.8/8.5	9.6/9.1/8.8
PUHY-M250YNW-A1(-BS)	-		400		21.8	6.3	8	0.92	14.1/13.4/12.9	13.8/13.1/12.6
PUHY-M300YNW-A1(-BS)	-		415		25.6	7.6	8	0.92	16.6/15.7/15.2	16.3/15.4/14.9

PUHY-EM-YNW-A1	Unit Combination	Units			Power supply	Compressor		FAN	RLA (A) (50/60Hz)	
		Hz	Volts	Voltage range		MCA (A)	Output (kW)		SC (A)	Output (kW)
PUHY-EM200YNW-A1(-BS)	-	50/60	380	Max:456V Min:342V	16.1	3.8	8	0.92	8.4/8.0/7.7	9.2/8.8/8.5
PUHY-EM250YNW-A1(-BS)	-		400		19.5	5.9	8	0.92	12.3/11.7/11.2	13.3/12.6/12.1
PUHY-EM300YNW-A1(-BS)	-		415		22.4	7.1	8	0.92	14.3/13.5/13.1	15.6/14.9/14.3

PUHY-M-YNW-A1, EM-YNW-A1

### 10-3. Power cable specifications

**Thickness of wire for main power supply, capacities of the switch and system impedance**

	Model	Minimum wire thickness (mm <sup>2</sup> )			Ground-fault interrupter *1	Local switch (A)		Breaker for wiring (A) (Non-fuse breaker)	Max. Permissible System Impedance
		Main cable	Branch	Ground		Capacity	Fuse		
Outdoor unit	PUHY-(E)M200YNW-A1	4.0	-	4.0	30A 100mA 0.1sec. or less	25	25	30	*2
	PUHY-(E)M250YNW-A1	4.0	-	4.0	30A 100mA 0.1sec. or less	32	32	30	*2
	PUHY-(E)M300YNW-A1	4.0	-	4.0	30A 100mA 0.1sec. or less	32	32	30	*2
Total operating current of the indoor unit	F0 = 20A or less *3	1.5	1.5	1.5	Current sensitivity *4	16	16	20	(apply to IEC61000-3-3)
	F0 = 30A or less *3	2.5	2.5	2.5	Current sensitivity *4	25	25	30	(apply to IEC61000-3-3)
	F0 = 40A or less *3	4.0	4.0	4.0	Current sensitivity *4	32	32	40	(apply to IEC61000-3-3)

\*1 The Ground-fault interrupter should support Inverter circuit. The Ground-fault interrupter should combine using of local switch or wiring breaker.

\*2 Meet technical requirements of IEC61000-3-3

\*3 Please take the larger of F1 or F2 as the value for F0.

F1 = Total operating maximum current of the indoor units × 1.2

F2 = {V1 × (Quantity of Type1)/C} + {V1 × (Quantity of Type2)/C} + {V1 × (Quantity of Type3)/C} + {V1 × (Quantity of Type4)/C}

Indoor unit		V1	V2
Type1	PEFY-VMA	18.6	3.0
Type2	PLFY-VEM	17.1	2.4

C: Multiple of tripping current at tripping time 0.01s

Please pick up "C" from the tripping characteristic of the breaker.

<Example of "F2" calculation>

\*Condition PEFY-VMA × 4 + PLYF-VEM × 1, C = 8 (refer to right sample chart)

F2 = 18.6 × 4/8 + 17.1 × 1/8

= 11.44

→16 A breaker (Tripping current = 8 × 16 A at 0.01s)

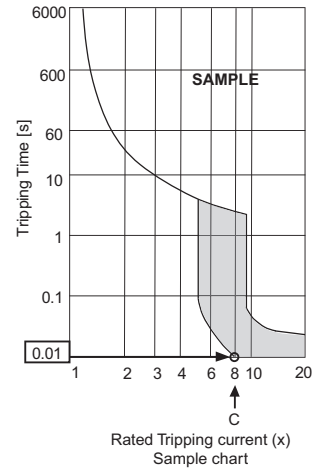

\*4 Current sensitivity is calculated using the following formula.

G1 = (V2 × Quantity of Type1) + (V2 × Quantity of Type2) + (V2 × Quantity of Type3) + (V2 × Quantity of Type4)

G1	Current sensitivity
30 or less	30 mA 0.1sec or less
100 or less	100 mA 0.1sec or less

Wire thickness	V3
1.5 mm <sup>2</sup>	48
2.5 mm <sup>2</sup>	56
4.0 mm <sup>2</sup>	66

- Use dedicated power supplies for the outdoor unit and indoor unit. Ensure OC and OS are wired individually.
- Bear in mind ambient conditions (ambient temperature, direct sunlight, rain water, etc.) when proceeding with the wiring and connections.
- The wire size is the minimum value for metal conduit wiring. If the voltage drops, use a wire that is one rank thicker in diameter. Make sure the power-supply voltage does not drop more than 10%. Make sure that the voltage imbalance between the phases is 2% or less.
- Specific wiring requirements should adhere to the wiring regulations of the region.
- Power supply cords of parts of appliances for outdoor use shall not be lighter than polychloroprene sheathed flexible cord (design 60245 IEC57). For example, use wiring such as YZW.
- A switch with at least 3 mm contact separation in each pole shall be provided when the Air Conditioner is installed.

#### ⚠ WARNING

- Be sure to use specified wires for connections and ensure no external force is imparted to terminal connections. If connections are not fixed firmly, heating or fire may result.
- Be sure to use the appropriate type of overcurrent protection switch. Note that generated overcurrent may include some amount of direct current.

#### ⚠ CAUTION

- The breakers for current leakage should support Inverter circuit. (e.g. Mitsubishi Electric's NV-S-Series or equivalent). If no earth leakage breaker is installed, it may cause an electric shock.
- Breakers for current leakage should combine using of switch.
- Do not use anything other than a breaker with the correct capacity. Using a breaker of too large capacity may cause malfunction or fire.
- If a large electric current flows due to malfunction or faulty wiring, earth-leakage breakers on the unit side and on the upstream side of the power supply system may both operate. Depending on the importance of the system, separate the power supply system or take protective coordination of breakers.

#### Note

- This device is intended for the connection to a power supply system with a maximum permissible system impedance shown in the above table at the interface point (power service box) of the user's supply.
- The user must ensure that this device is connected only to a power supply system which fulfils the requirement above. If necessary, the user can ask the public power supply company for the system impedance at the interface point.
- This equipment complies with IEC 61000-3-12 provided that the short-circuit power Ssc is greater than or equal to Ssc (\*2) at the interface point between the user's supply and the public system. It is the responsibility of the installer or user of the equipment to ensure, by consultation with the distribution network operator if necessary, that the equipment is connected only to a supply with a short-circuit power Ssc greater than or equal to Ssc (\*2).

Ssc(\*2)

Model	Ssc (MVA)
PUHY-M200YNW-A1	1.25
PUHY-M250YNW-A1	1.38
PUHY-M300YNW-A1	1.76

Model	Ssc (MVA)
PUHY-EM200YNW-A1	1.25
PUHY-EM250YNW-A1	1.27
PUHY-EM300YNW-A1	1.58

10-4. Power supply examples

The local standards and/or regulations is applicable at a higher priority.

10-4-1. PUHY-(E)M200, 250, 300YNW-A1

PUHY-M-YNW-A1, EM-YNW-A1

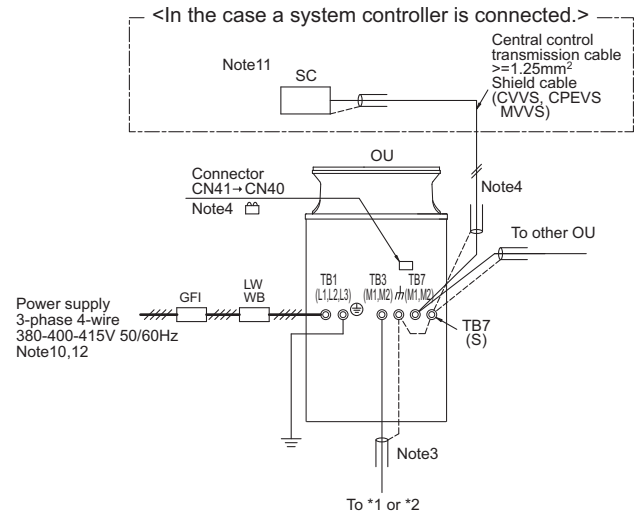

- Note:
- The transmission cable is not-polarity double-wire.
  - Symbol Ⓞ means a screw terminal for wiring.
  - The shield wire of transmission cable should be connected to the grounding terminal at Outdoor unit. All shield wire of M-Net transmission cable among Indoor units should be connected to the S terminal at Indoor unit or all shield wire should be connected together. The broken line at the scheme means shield wire.
  - When the Outdoor unit connected with system controller, power-supply to TB7 of the outdoor unit(s) is needed. The connector change from CN41 to CN40 at one of the outdoor units will enable the outdoor unit to supply power to TB7, or an extra power supplying unit PAC-SC51KUA should be used. The transmission cable (above 1.25mm², shielded, CVVS/CPEVS/MVVS) among Outdoor units and system controllers is called central control transmission cable. The shield wire of the central control transmission cable must be grounded at the Outdoor unit whose CN41 is changed to CN40. When the power supplying unit PAC-SC51KUA is used, connect the shielded cable to the ground terminal on the PAC-SC51KUA.
  - MA R/C transmission cable (0.3-1.25mm²) must be less than 200m in length, while ME R/C transmission cable (0.3-1.25mm²) must be less than 10m in length. But transmission cable to the ME R/C can be extended using a M-NET cable (>=1.25mm²) when the length is counted in the M-Net length.
  - MA remote controller and ME remote controller should not be grouped together. When a PAR-CT01MA or PAR-4X MA-Series (X indicates 1, 2, ...) is connected to a group, no other MA remote controllers can be connected to the same group.
  - If using 1 or 2 (main/sub) MA remote controller to control more than 1 Indoor unit, use MA transmission cable to connect all the TB15 terminals of the Indoor units. It is called "Grouping".
  - If using 1 or 2 (main/sub) ME remote controller control more than 1 indoor unit, set address to Indoor unit and ME remote controller. For the method, refer to 11-4. "Address setting".
  - Indoor board consumes power from TB3. The power balance should be considered according to System Design 11-3. "System configuration restrictions".
  - If Transmission booster is needed, be sure to connect the shield wires to the both sides to the booster.
  - The critical current for choosing power source equipment is approximate 1.4 times of total rated current of the Outdoor unit(s) or Indoor unit(s).
  - When System controller (SC) is connected to the system, turn the SW5-1 on.
  - The phases of electricity power must be confirmed to be right used. Phase-reverse, or phase-missing could break the controllers.

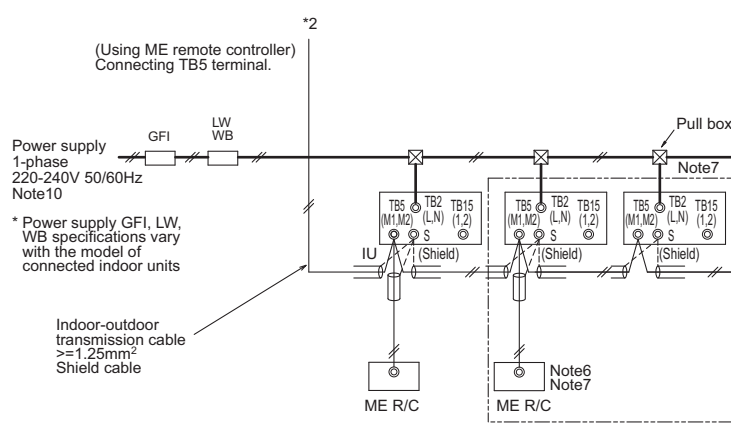
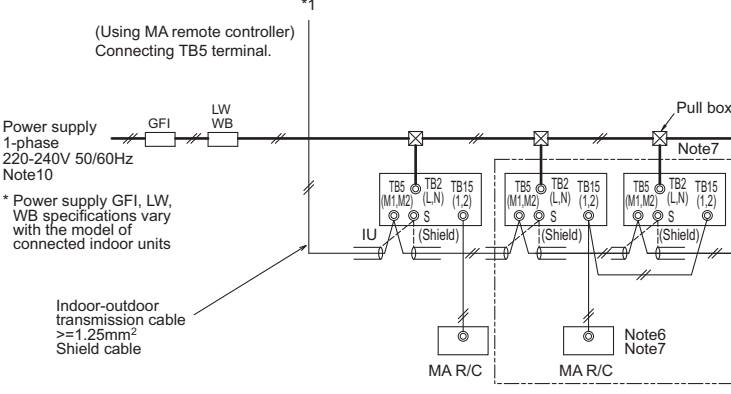

Symbol	Model	Ground-fault interrupter *1, *2, *4	Local switch		Wiring breaker*4 (NFB) <A>	Minimum Wire thickness				
			BKC <A>	OCP*3, *4 <A>		Power wire <mm²>	Earth wire <mm²>			
GFI	Ground-fault interrupter	PUHY-(E)M200YNW-A1	30A	100mA	0.1sec. or less	25	25	30	4	4
LW	Local switch	PUHY-(E)M250YNW-A1	30A	100mA	0.1sec. or less	32	32	30	4	4
BKC	Breaker capacity	PUHY-(E)M300YNW-A1	30A	100mA	0.1sec. or less	32	32	30	4	4
OCP	Over-current protector									
WB	Wiring breaker									
NFB	Non-fuse breaker									
OU	Outdoor unit									
IU	Indoor unit									
SC	System controller									
MA R/C	MA remote controller									
ME R/C	ME remote controller									

\*1 The Ground-fault interrupter should support Inverter circuit. (e.g. Mitsubishi Electric's NV-S-Series or equivalent).  
 \*2 Ground-fault interrupter should combine using of local switch or wiring breaker.  
 \*3 It shows data for B-type fuse of the breaker for current leakage.  
 \*4 If a large electric current flows due to malfunction or faulty wiring, earth-leakage breakers on the unit side and on the centralized controller side may both operate.  
 Depending on the importance of the system, separate the power supply system or take protective coordination of breakers.

11-1. Transmission cable length limitation

11-1-1. Using MA Remote controller

Long transmission cable causes voltage down, therefore, the length limitation should be obeyed to secure proper transmission.

Max. length via Outdoor (M-NET cable)	$L1+L2+L3, L1+L2+L4+L5, L3+L4+L5, L6+L2+L3, L6+L2+L4+L5$	$\leq 500m(1000m^*1)[1640ft.(3280ft.^*1)]$	1.25mm <sup>2</sup> [AWG16] or thicker
Max. length to Outdoor (M-NET cable)	$L1+L6, L3, L2+L4+L6, L5$	$\leq 200m[656ft.]$	1.25mm <sup>2</sup> [AWG16] or thicker
Max. length from MA to Indoor for each group	$a1+a2, a1+a2+a3+a4$	$\leq 200m[656ft.]$	0.3-1.25 mm <sup>2</sup> [AWG22-16]
24VDC to AG-150A	n	$\leq 50m[164ft.]$	0.75-2.0 mm <sup>2</sup> [AWG18-14]

\*1 When the wiring length exceeds 500 m (1640 ft), consult the sales office.

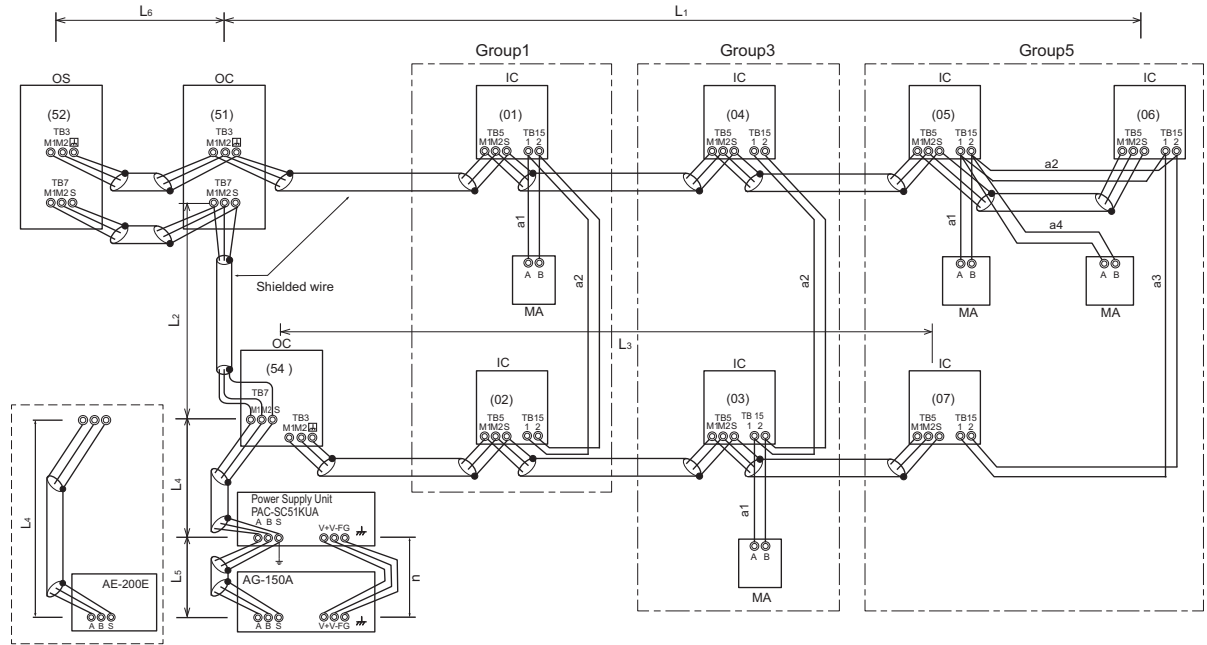

OC, OS: Outdoor unit controller; IC: Indoor unit controller; MA: MA remote controller

11-1-2. Using ME Remote controller

Long transmission cable causes voltage down, therefore, the length limitation should be obeyed to secure proper transmission.

Max. length via Outdoor (M-NET cable)	$L1+L2+L3+L4, L1+L2+L6+L7, L1+L2+L3+L5, L3+L4+L6+L7, L8+L2+L3+L4, L8+L2+L3+L5, L8+L2+L6+L7, L3+L5+L6+L7$	$\leq 500m(1000m^*1)[1640ft.(3280ft.^*1)]$	1.25mm <sup>2</sup> [AWG16] or thicker
Max. length to Outdoor (M-NET cable)	$L1+L8, L3+L4, L2+L6+L8, L7, L3+L5$	$\leq 200m[656ft.]$	1.25mm <sup>2</sup> [AWG16] or thicker
Max. length from ME to Indoor	$e1, e2, e3, e4$	$\leq 10m[32ft.]^*2$	0.3-1.25 mm <sup>2</sup> [AWG22-16] *2
24VDC to AG-150A	n	$\leq 50m[164ft.]$	0.75-2.0 mm <sup>2</sup> [AWG18-14]

\*1 When the wiring length exceeds 500 m (1640 ft), consult the sales office.

\*2. If the length from ME to Indoor exceed 10m, use 1.25 mm<sup>2</sup> [AWG16] shielded cable, but the total length should be counted into Max. length via Outdoor.

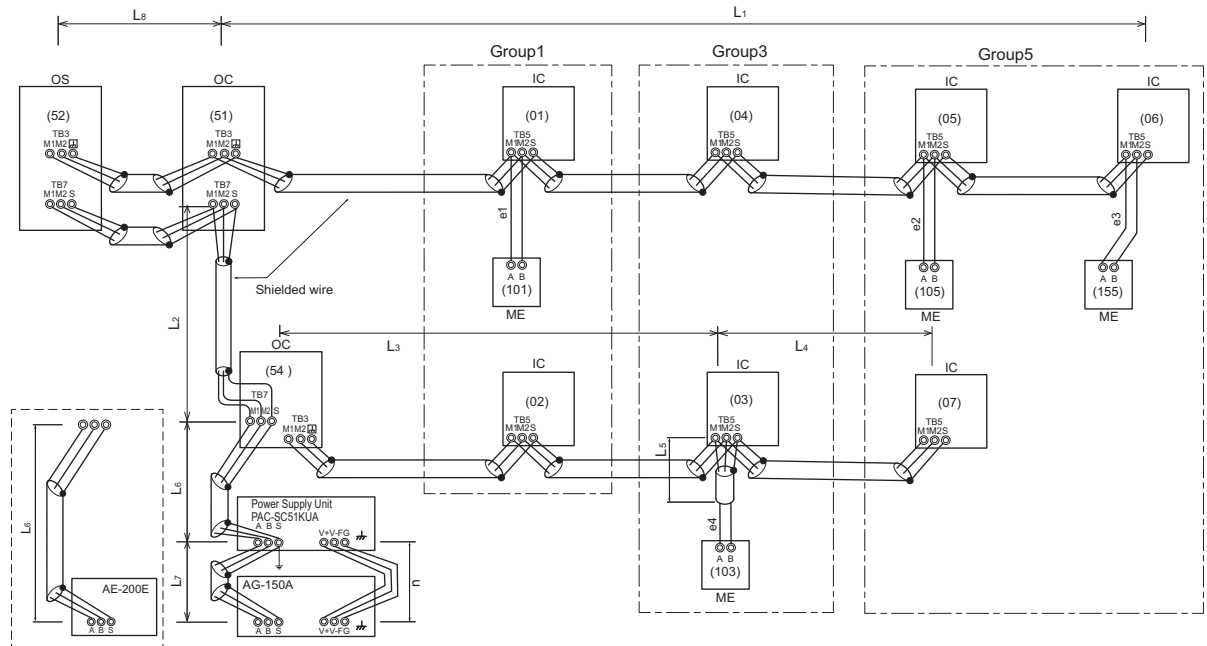

OC, OS: Outdoor unit controller; IC: Indoor unit controller; ME: ME remote controller

## 11-2. Transmission cable specifications

	Transmission cables (Li)	M-NET remote controller cables (ei)	MA Remote controller cables (ai)
Type of cable	Shielding wire (2-core) CVVS, CPEVS or MVVS	Sheathed 2-core cable (unshielded) CVV	
Cable size	More than 1.25 mm <sup>2</sup> [AWG16]	0.3 ~ 1.25 mm <sup>2</sup> [AWG22~16]	0.3 ~ 1.25 mm <sup>2</sup> [AWG22 ~16]*1
Remarks	Max length: within 200 m	When 10 m [32ft] is exceeded, use cables with the same specification as transmission cables.	Max length: 200 m [656ft]

\*1 To wire PAR-CT01MA, PAR-4xMAA, PAR-3xMAA ("x" represents 0 or later), and Simple MA remote controller, use a wire with a diameter of 0.3 mm<sup>2</sup> [AWG22]

CVVS, MVVS: PVC insulated PVC sheathed shielded control cable  
CPEVS: PE insulated PVC sheathed shielded communication cable  
CVV: PVC insulated PVC sheathed control cable



### 11-3. System configuration restrictions

#### 11-3-1. Common restrictions for the CITY MULTI system

For each Outdoor/Heat source unit, the maximum connectable quantity of Indoor unit is specified at its Specifications table.

- A) 1 Group of Indoor units can have 1-16 Indoor units;
  - \*OA processing unit GUF-RD(H) is considered as Indoor unit.
- B) Maximum 2 remote controllers for 1 group;
  - \*MA/ME remote controllers cannot be present together in 1group.
  - \*When a PAR-CT01MA, PAR-40MA, or PAR-3X MA-Series (X indicates 1, 2...) is connected to a group, no other MA remote controllers can be connected to the same group.
- C) 1 Lossnay unit can interlock maximum 16 Indoor units; 1 Indoor unit can interlock only 1 Lossnay unit.
- D) Maximum 3 System controllers are connectable when connecting to TB3 of the Outdoor/Heat source unit.
- E) A maximum of 6 system controller are connectable to TB3 and TB7 of Outdoor/Heat source unit.
- F) 4 System controllers or more are connectable when connecting to TB7 of the Outdoor/Heat source unit, if the transmission power is supplied by the power supply unit PAC-SC51KUA.
  - \*System controller connected as described in D) would have a risk that the failure of connected Outdoor/Heat source unit would stop power supply to the System controller.

#### 11-3-2. Ensuring proper communication power and the number of connected units for M-NET

In order to ensure proper communication among Outdoor/Heat source unit, Indoor unit, Lossnay, OA processing unit GUF-RD(H), and Controllers, the transmission power situation for the M-NET should be observed. In some cases, Transmission booster should be used. Taking the power consumption of Indoor unit as 1, the equivalent power consumption or supply of others are listed at Table 1 and Table 2.

Both the transmission line for centralized controller and indoor-outdoor transmission line must meet the conditions listed below. (Both conditions a) and b) must be met.)

a) [Total equivalent power consumption] ≤ [The equivalent power supply]

b) [Total equivalent number of units (Table 1)] ≤ [40]

Table 1 The equivalent power consumption and the equivalent number of units

Category	Model	The equivalent power consumption	The equivalent number of units
CITY MULTI indoor unit OA unit CITY MULTI connection kit Air handling unit controller	Except for the models indicated by *2 PEFY-AF2500, 3000, 4000, 5000, 6000MH GUF-50, 100 PAC-LV11M-J PAC-AH125, 140, 250, 500M-J	1	1
CITY MULTI indoor unit *2	PDFY-P100VM-E-RE	2	2
BC controller	CMB	2	1
PWFY *1	P100VM-E-BU	6	1
	P200VM-E1-AU P200VM-E2-AU	5	1
	(E)P100VM-E1-AU (E)P100VM-E2-AU P140VM-E1-AU P140VM-E2-AU	1	1
PFAV	P250, 300, 500, 600VM-E(-F)	1	1
	P750, 900VM-E(-F)	2	2
PFV, PEV	P200, 250, 400, 500YM-A	1	1
MA remote controller/Lossnay	PAR-CT01MA PAR-21MA PAR-31MA PAR-32MA PAR-33MA PAR-40MA PAC-YT52CRA PAR-FA32MA LGH PZ-60DR-E PZ-61DR-E PZ-43SMF-E	0	0
ME remote controller	PAR-U02MEDA	0.5	1
	PZ-52SF	0.25	1
System controller	AE-200E AE-50E EW-50E LM-AP	0	0
	AG-150A EB-50GU-J PAC-IF01AHC-J	0.5	1
	AT-50B	1.5	5
	PAC-YG60MCA PAC-YG66DCA PAC-YG63MCA	0.25	1
ON/OFF controller	PAC-YT40ANRA	1	1
MN converter	CMS-MNG-E	2	1
Outdoor/Heat source unit	TB7 power consumption	0	0
System control interface	MAC-333IF-E	0	0
A-M converter	PAC-SF83MA-E		

\*1 PWFY cannot be connected to PUMY model.

Table 2 The equivalent power supply

Category	Model	The equivalent power supply		
Transmission Booster	PAC-SF46EPA-G	25 *1		
Power supply unit	PAC-SC51KUA	5		
Expansion controller	PAC-YG50ECA	6		
BM ADAPTER	BAC-HD150	6		
System controller	AE-200E/AE-50E	0.75		
	EW-50E	1.5		
	LM-AP	0		
Outdoor/Heat source unit		TB3 and TB7 total	TB7 only	TB3 only
	Outdoor unit except S-Series and TKA *2	32 *1	6	32 *1-equivalent power supplied to TB7
	S-Series outdoor unit	12 *1	0	12 *1
	TKA outdoor unit	32 *1	- *3	32 *1

\*1 When one or more indoor units listed below is connected, subtract 3 from the equivalent power supply.

Table 3

Category	Model
Indoor unit	Sized P200/P250
	PEFY-AF4000/5000/6000MH, PFFY-P400/500YM-E, PFFY-P400/500YMH-C
	PFFY-P300/600YM-E-F, PFFY-P300/600YM-C-F, PDFY-P100VM-E-RE
Air handling unit controller	PAC-AH250/500M-J
PFAV	PFAV-P500/600/750/900VM-E(-F)
PFV	PFV-P400/500YM-A
PEV	PEV-P400/500YM-A

\*2 If PAC-SC51KUA is used to supply power at TB7 side, no power supply need from Outdoor/Heat source unit at TB7, Connector TB3 itself will therefore have 32.

\*3 Do not supply power to TB7 from TKA outdoor units.

Use PAC-SC51KUA or PAC-SF46EPA-G when connecting an M-NET device to TB7.

With the equivalent power consumption values and the equivalent number of units in Table 1 and Table 2, PAC-SF46EPA-G can be designed into the air-conditioner system to ensure proper system communication according to (A), (B), (C).

- (A) Firstly, count from TB3 at TB3 side the total equivalent number of units of Indoor units, OA processing units, ME remote controller, and System controllers. If the total equivalent number of units reaches 40, a PAC-SF46EPA-G should be set.
- (B) Secondly, count from TB7 side to TB3 side the total transmission power consumption. If the total equivalent power supply reaches 32, a PAC-SF46EPA-G should be set. Yet, if a PAC-SC51KUA or another controller with a built-in power supply, such as PAC-YG50ECA, is used to supply power at TB7 side, count from TB3 side only.
- (C) Thirdly, count from TB7 at TB7 side the total transmission power consumption, If the total equivalent power supply for only TB7 reaches 6, a PAC-SF46EPA-G should be set. Also, count from TB7 at TB7 side the total equivalent number of units of System controllers, and so on. If the total equivalent number of units reaches 40, a PAC-SF46EPA-G should be set.

\* The equivalent power supply of S-Series outdoor unit is 12.

\* When one or more indoor units listed in Table 3 is connected, subtract 3 from the equivalent power supply.

■ System example

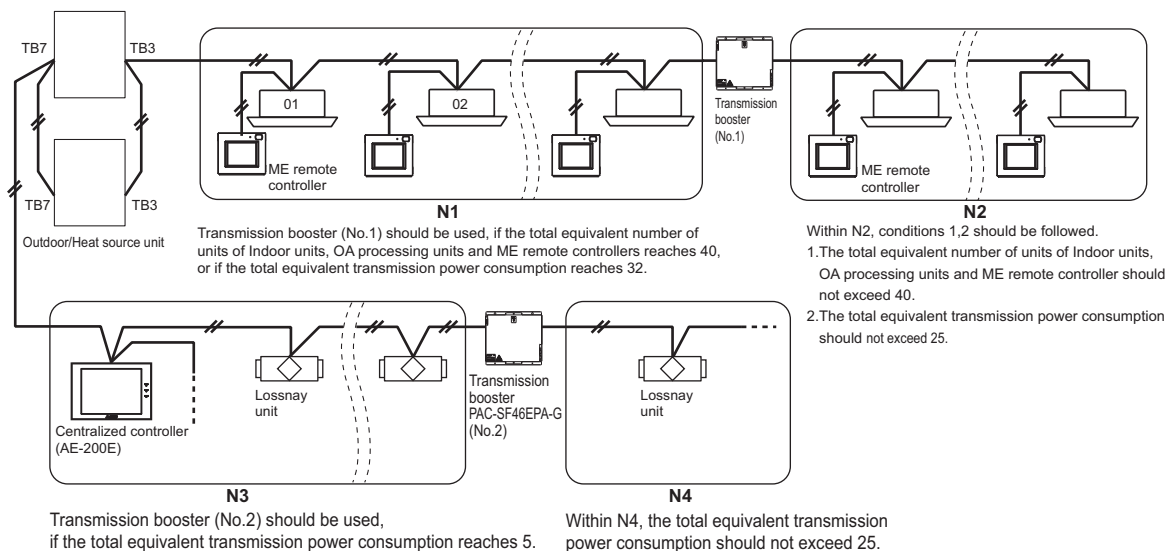

PUHY-M-YNW-A1, EM-YNW-A1

### 11-3-3. Ensuring proper power supply to System controller

The power to System controller (excluding AE-200E, AE-50E, EW-50E, BAC-HD150, LM-AP) is supplied via M-NET transmission line. M-NET transmission line at TB7 side is called Centralized control transmission line while one at TB3 side is called Indoor-Outdoor/Heat source transmission line. There are 3 ways to supply power to the System controller.

- A) Connecting to TB3 of the Outdoor/Heat source unit and receiving power from the Outdoor/Heat source unit.
- B) Connecting to TB7 of the Outdoor/Heat source unit and receiving power from the Outdoor/Heat source unit. (Not applicable to the PUMY model)
- C) Connecting to TB7 of the Outdoor/Heat source unit but receiving power from power supply unit PAC-SC51KUA.

\* System controllers (AE-200E, AE-50E, EW-50E, BAC-HD150, LM-AP) have a built-in function to supply power to the M-NET transmission lines, so no power needs to be supplied to the M-NET transmission lines from the Outdoor/Heat source units or from PAC-SC51KUA.

#### 11-3-3-A. When connecting to TB3 of the Outdoor/Heat source unit and receiving power from the Outdoor/Heat source unit.

Maximum 3 System controllers can be connected to TB3. If there is more than 1 Outdoor/Heat source unit, it is necessary to replace power supply switch connector CN41 with CN40 on one Outdoor/Heat source unit.

Fig. 11-3-3-A

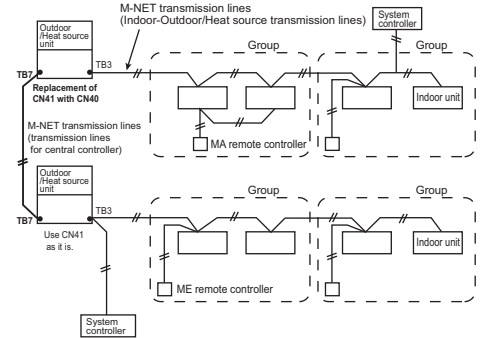

#### 11-3-3-B. When connecting to TB7 of the Outdoor/Heat source unit and receiving power from the Outdoor/Heat source unit. (Not applicable to the PUMY model)

A maximum of 6 system controller are connectable to TB3 and TB7 of Outdoor/Heat source unit. (Not applicable to the PUMY model) It is necessary to replace power supply switch connector CN41 with CN40 on one Outdoor/Heat source unit.

Fig. 11-3-3-B

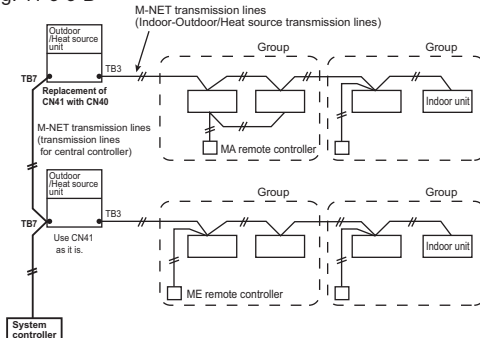

#### 11-3-3-C. When connecting to TB7 of the Outdoor/Heat source unit but receiving power from PAC-SC51KUA.

When using PAC-SC51KUA to supply transmission power, the power supply connector CN41 on the Outdoor/Heat source units should be kept as it is. It is also a factory setting. 1 PAC-SC51KUA supports maximum 1 AG-150A or 1 EB-50GU-J unit due to the limited power 24VDC at its TB3. However, 1 PAC-SC51KUA supplies transmission power at its TB2 equal to 5 Indoor units, which is referable at Table 2. If System controller, ON/OFF controller connected to TB7 consume transmission power more than 5 (Indoor units), Transmission booster PAC-SF46EPA-G is needed. PAC-SF46EPA-G supplies transmission power equal to 25 Indoor units.

Fig. 11-3-3-C

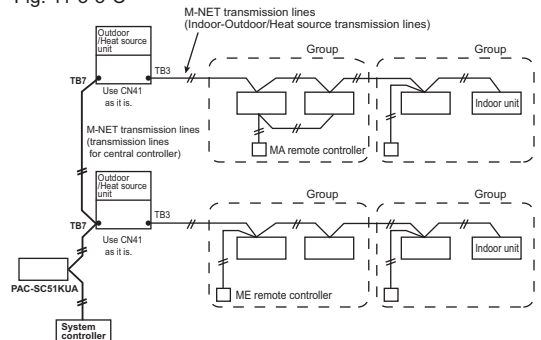
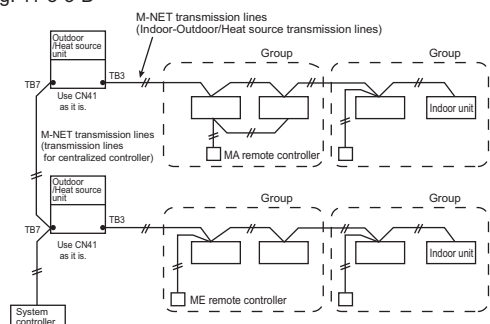

Fig. 11-3-3-D



### CAUTION

- AG-150A/EB-50GU-J\*1 are recommended to connect to TB7 because it performs back-up to a number of data.
- In an air conditioner system has more than 1 Outdoor/Heat source units, AG-150A/EB-50GU-J receiving transmission power at TB3 or TB7 on one of the Outdoor/Heat source units would have a risk that the connected Outdoor/Heat source unit failure would stop power supply to AG-150A/EB-50GU-J, and disrupt the whole system.
- When applying apportioned electric power function, AG-150A/EB-50GU-J are necessary to connected to TB7 and has its own power supply unit PAC-SC51KUA.
- Note: Power supply unit PAC-SC51KUA is for AG-150A/EB-50GU-J.
- \*1: AG-150A is an example model of system controllers.
- How to connect system controllers (AE-200E, AE-50E, EW-50E, BAC-HD150, LM-AP) to a given system
- System controllers (AE-200E, AE-50E, EW-50E, BAC-HD150, LM-AP) have a built-in function to supply power to the M-NET transmission lines, so no power needs to be supplied to the M-NET transmission lines from the Outdoor/Heat source units or from PAC-SC51KUA.
- Leave the power supply connector on the Outdoor/Heat source unit connected to CN41 as it is.
- Refer to 11-3-2 for information about the power-supply capacity of each system controller (EW-50E, BAC-HD150, LM-AP) to the low-level system controllers.

**11-3-4. Power supply to LM-AP**

1-phase 220-240VAC power supply is needed.

The power supply unit PAC-SC51KUA is not necessary when connecting only the LM-AP. Yet, make sure to change the power supply changeover connector CN41 to CN40 on the LM-AP.

**11-3-5. Power supply to expansion controller**

1-phase 100-240VAC power supply is needed.

The power supply unit PAC-SC51KUA is not necessary.

The expansion controller supplies power through TB3, which equals 6 indoor units. (refer to Table 2)

**11-3-6. Power supply to BM ADAPTER**

1-phase 100-240VAC power supply is needed.

The power supply unit PAC-SC51KUA is not necessary when only BM ADAPTER is connected.

Yet, make sure to move the power jumper from CN41 to CN40 on the BM ADAPTER.

**11-3-7. Power supply to AE-200E/AE-50E/EW-50E**

1-phase 100-240VAC power supply is needed.

The power supply unit PAC-SC51KUA is not necessary when connecting only the AE-200E/AE-50E/EW-50E.

## 11-4. Address setting

### 11-4-1. Switch operation

In order to constitute CITY MULTI in a complete system, switch operation for setting the unit address No. and connection No. is required.

- ① Address No. of outdoor unit, indoor unit and remote controller.  
The address No. is set at the address setting board.  
In the case of R2 system, it is necessary to set the same No. at the branch No. switch of indoor unit as that of the BC controller connected. (When connecting two or more branches, use the lowest branch No.)

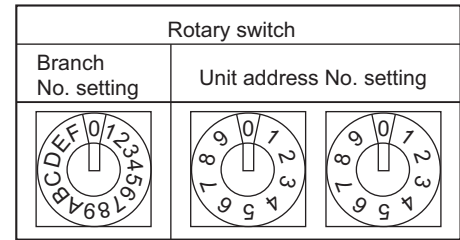

- ② Caution for switch operations

- Be sure to shut off power source before switch setting. If operated with power source on, switch can not operate properly.
- No units with identical unit address shall exist in one whole air conditioner system. If set erroneously, the system can not operate.

- ③ MA remote controller

- When connecting only one remote controller to one group, it is always the main remote controller. When connecting two remote controllers to one group, set one remote controller as the main remote controller and the other as the sub remote controller.
- The factory setting is "Main".

PAR-3X MA-Series (X indicates 1, 2...), PAR-CT01MA  
The MA remote controller does not have the switches listed above.  
Refer to the installation manual for the function setting.

#### PAC-YT52CRA





































##### Setting the dip switches

There are switches on the back of the top case. Remote controller Main/Sub and other function settings are performed using these switches. Ordinarily, only change the Main/Sub setting of SW1.  
(The factory settings are ON for SW1, 2, and 3 and OFF for SW4.)

SW No.	SW contents Main	ON	OFF	Comment
1	Remote controller Main/Sub setting	Main	Sub	Set one of the two remote controllers at one group to "ON".
2	Temperature display units setting	Celsius	Fahrenheit	When the temperature is displayed in [Fahrenheit], set to "OFF".
3	Cooling/heating display in AUTO mode	Yes	No	When you do not want to display "Cooling" and "Heating" in the AUTO mode, set to "OFF".
4	Indoor temperature display	Yes	No	When you want to display the indoor temperature, set to "ON".

PUHY-M-YNW-A1, EM-YNW-A1

11-4-2. Rule of setting address

Unit	Address setting	Example	Note
Indoor unit System control interface (MAC-333IF-E) A-M converter (PAC-SF83MA-E) Air handling unit controller (PAC-AH125, 140, 250, 500M-J) CITY MULTI connection Kit (PAC-LV11M-J)	01 ~ 50	 	Use the most recent address within the same group of indoor units. Make the indoor units address connected to the BC controller (Sub) larger than the indoor units address connected to the BC controller (Main). If applicable, set the sub BC controllers in an PURY system in the following order: (1) Indoor unit to be connected to the BC controller (Main) (2) Indoor unit to be connected to the BC controller (No.1 Sub) (3) Indoor unit to be connected to the BC controller (No.2 Sub) Set the address so that (1)<(2)<(3) A maximum of 12 BC controllers are connectable.
Outdoor unit	51 ~ 99, 100 (Note1)	 	The smallest address of indoor unit in same refrigerant system + 50 Assign sequential address numbers to the outdoor units in one refrigerant circuit system. OC, OS1 and OS2 are automatically detected. (Note 2) * Please reset one of them to an address between 51 and 99 when two addresses overlap. * The address automatically becomes "100" if it is set as "01~ 50"
BC controller (Main)	52 ~ 99, 100	 	The address of outdoor unit + 1 * Please reset one of them to an address between 51 and 99 when two addresses overlap. * The address automatically becomes "100" if it is set as "01~ 50"
BC controller (Sub)	52 ~ 99, 100	 	Lowest address within the indoor units connected to the BC controller (Sub) plus 50.
Local remote controller	ME Remote controller (Main)	1 Fixed  	The smallest address of indoor unit in the group + 100 * The place of "100" is fixed to "1"
	ME Remote controller (Sub)	1 Fixed  	The address of main remote controller + 50 * The address automatically becomes "200" if it is set as "00"
System controller	ON/OFF remote controller	  	The smallest group No. to be managed + 200 * The smallest group No. to be managed is changeable.
	AE-200E/AE-50E AG-150A EB-50GU-J EW-50E AT-50B	0,2  0~5  0~9 	* AT-50B cannot be set to "000".
	PAC-YG50ECA	0,2  0~5  0~9 	* Settings are made on the initial screen of AG-150A.
	BAC-HD150	0,2  0~5  0~9 	* Settings are made with setting tool of BM ADAPTER.
	LMAP04-E	2 Fixed  	
PI, AI, DIDO	PAC-YG60MCA	 	
	PAC-YG63MCA	 	
	PAC-YG66DCA	 	
Lossnay, OA processing unit	01 ~ 50	 	After setting the addresses of all the indoor units, assign an arbitrary address.
PAC-IF01AHC	201 ~ 250	2 Fixed  	

Note1: To set the address to "100", set it to "50"

Note2: Outdoor units OC, OS1 and OS2 in one refrigerant circuit system are automatically detected. OC, OS1 and OS2 are ranked in descending order of capacity. If units are the same capacity, they are ranked in ascending order of their address.

### 11-4-3. System examples

#### Factory setting

Original switch setting of the outdoors, indoors, controllers, LM-AP and BM ADAPTER at shipment is as follows.

- Outdoor unit : Address: 00, CN41: ON (Jumper), DipSW5-1: OFF
- Indoor unit : Address: 00
- ME remote controller : Address: 101
- LM-AP : Address: 247, CN41: ON (Jumper), DipSW1-2: OFF
- BM ADAPTER : Address: 000, CN41: ON (Jumper)
- AE-200E/AE-50E/EW-50E : Address: 000, CN21: ON (Jumper)

#### Setting at the site

- DipSW5-1(Outdoor) : When the System Controller is used, all the Dip SW5-1 at the outdoor units should be set to "ON". \* Dip SW5-1 remains OFF when only LM-AP is used.
- DipSW1-2(LM-AP) : When the LM-AP is used together with System Controller, DipSW1-2 at the LM-AP should be set to "ON".
- CN40/CN41 : Change jumper from CN41 to CN 40 at outdoor control board will activate central transmission power supply to TB7;  
(Change jumper at only one outdoor unit when activating the transmission power supply without using a power supply unit.)  
Change jumper from CN41 to CN 40 at LM-AP/BM ADAPTER will activate transmission power supply to LM-AP/BM ADAPTER itself;  
Power supply unit is recommended to use for a system having more than 1 outdoor unit, because the central transmission power supply from TB7 of one of outdoor units is risking that the outdoor unit failure may let down the whole system controller system.
- CN21(AE-200E/AE-50E/EW-50E) : Activates the power supply to M-NET transmission line from AE-200E/AE-50E/EW-50E (CN21: ON (power supplied), OFF (power not supplied))

#### 11-4-3-1. MA remote controller, Single-refrigerant-system, No System Controller

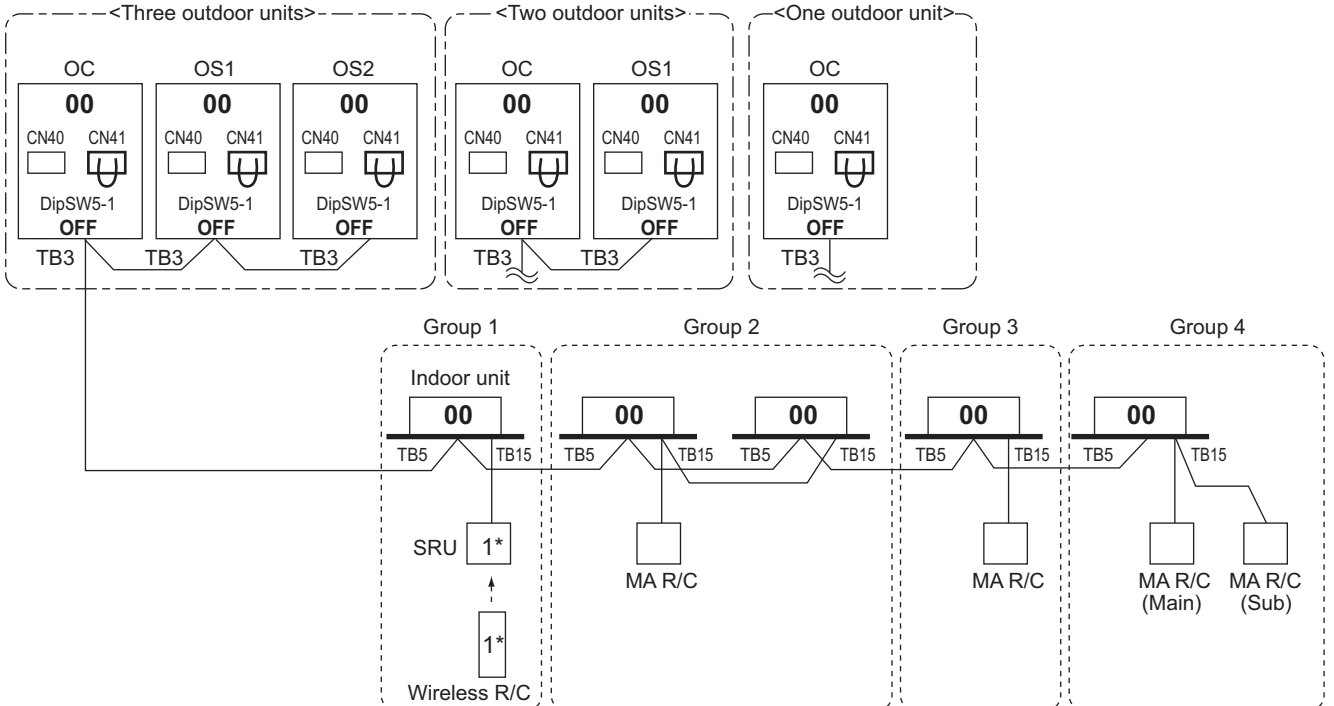

\*1 For Wireless R/C and Signal receiver unit (SRU), channel 1, 2 and 3 are selectable and should be set to same channel.

**NOTE:**

1. Outdoor units OC, OS1 and OS2 in one refrigerant circuit system are automatically detected. OC, OS1 and OS2 are ranked in descending order of capacity. If units are the same capacity, they are ranked in ascending order of their address.
2. No address setting is needed.
3. For a system having more than 32 indoor unit, confirm the need of Booster at 11-3. **"System configuration restrictions"**.
4. When a PAR-CT01MA or PAR-4X MA-Series (X indicates 1, 2...) is connected to a group, no other MA remote controllers can be connected to the same group.

PUHY-M-YNW-A1, EM-YNW-A1

11-4-3-2. MA remote controller, Single-refrigerant-system, System Controller

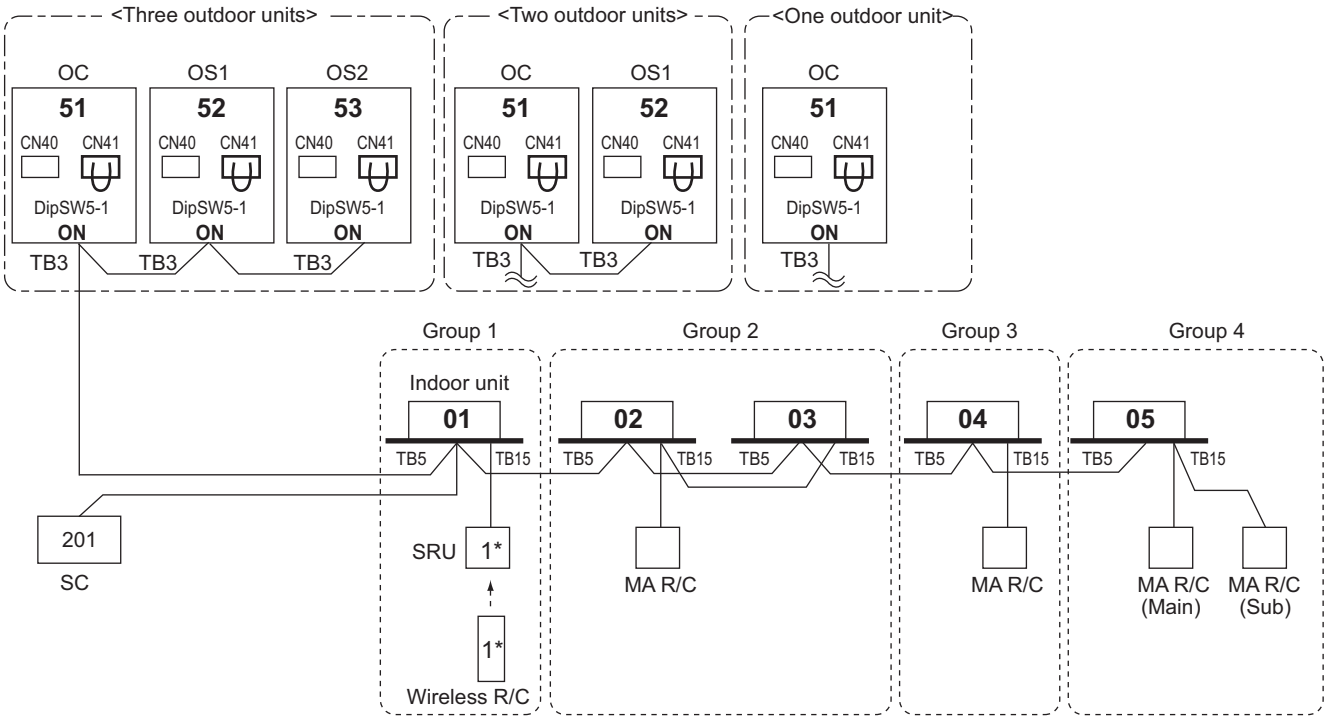

\*1 For Wireless R/C and Signal receiver unit (SRU), channel 1, 2 and 3 are selectable and should be set to same channel.  
 \*SC can be connected to TB3 side or TB7 side;  
 Should SC connected to TB7 side, change Jumper from CN41 to CN40 at the Outdoor unit module so as to supply power to the SC.

NOTE:

1. Outdoor units OC, OS1 and OS2 in one refrigerant circuit system are automatically detected.  
 OC, OS1 and OS2 are ranked in descending order of capacity. If units are the same capacity, they are ranked in ascending order of their address.
2. Address should be set to Indoor units and centralized controller.
3. For a system having more than 32 indoor unit, confirm the need of Booster at 11-3. **"System configuration restrictions"**.
4. When a PAR-CT01MA or PAR-4X MA-Series (X indicates 1, 2...) is connected to a group, no other MA remote controllers can be connected to the same group.



11-4-3-3. MA remote controller, Multi-refrigerant-system, System Controller at TB7/TB3 side, Booster for long M-NET wiring

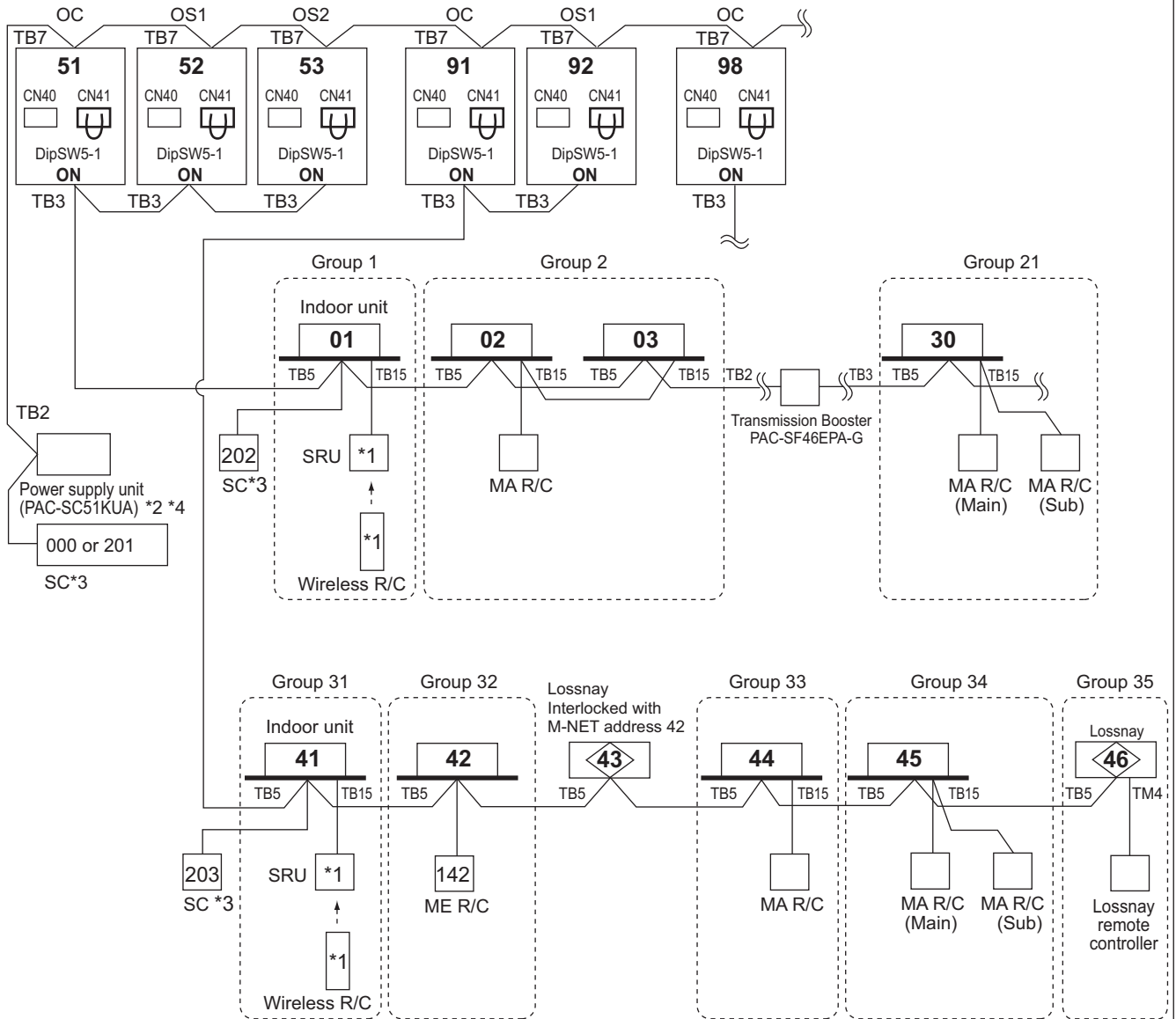

\*1 For Wireless R/C and Signal receiver unit (SRU), channel 1, 2 and 3 are selectable and should be set to same channel.

\*2 System controller should connect to TB7 at Outdoor and use power supply unit together in Multi-Refrigerant-System.  
 For AG-150A, 24V DC should be used with the PAC-SC51KUA.  
 For AE-200E, AE-50E, and EW-50E the power supply unit PAC-SC51KUA is unused.

\*3 When multiple system controllers are connected in the system, set the controller with more functions than others as a "main" controller and others as "sub".  
 AE-200E, AE-50E, EW-50E, and BAC-HD150 are for exclusive use as a "main" system controller and cannot be used as a "sub" system controller.  
 Make the setting to only one of the system controllers for "prohibition of operation from local remote controller".

\*4 The power supply unit is not necessary for AE-200E, AE-50E, EW-50E, BAC-HD150, and LM-AP.

NOTE:

- Outdoor units OC, OS1 and OS2 in one refrigerant circuit system are automatically detected.  
 OC, OS1 and OS2 are ranked in descending order of capacity. If units are the same capacity, they are ranked in ascending order of their address.
- Address should be set to Indoor units, Lossnay, and system controller.
- M-NET power is supplied by the Outdoor unit at TB3, while Indoor unit and ME remote controller consume the M-NET power for transmission use. The power balance is needed to consider for long M-NET wiring.  
 Details refer to 11-3. "System configuration restrictions".
- When a PAR-CT01MA or PAR-4X MA-Series (X indicates 1, 2...) is connected to a group, no other MA remote controllers can be connected to the same group.

PUHY-M-YNW-A1, EM-YNW-A1

11-4-3-4. ME remote controller, Single-refrigerant-system, No system controller

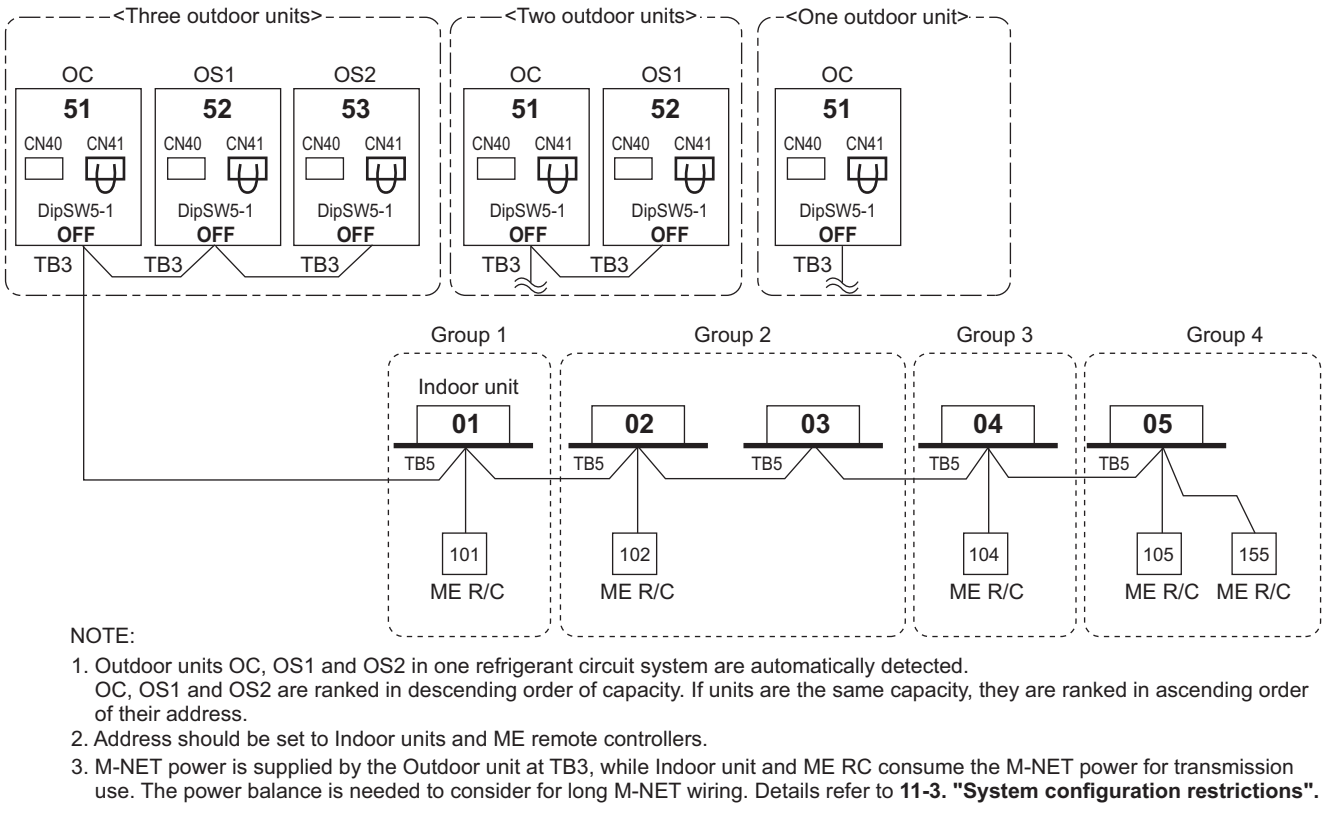

11-4-3-5. ME remote controller, Single-refrigerant-system, System controller, Lossnay

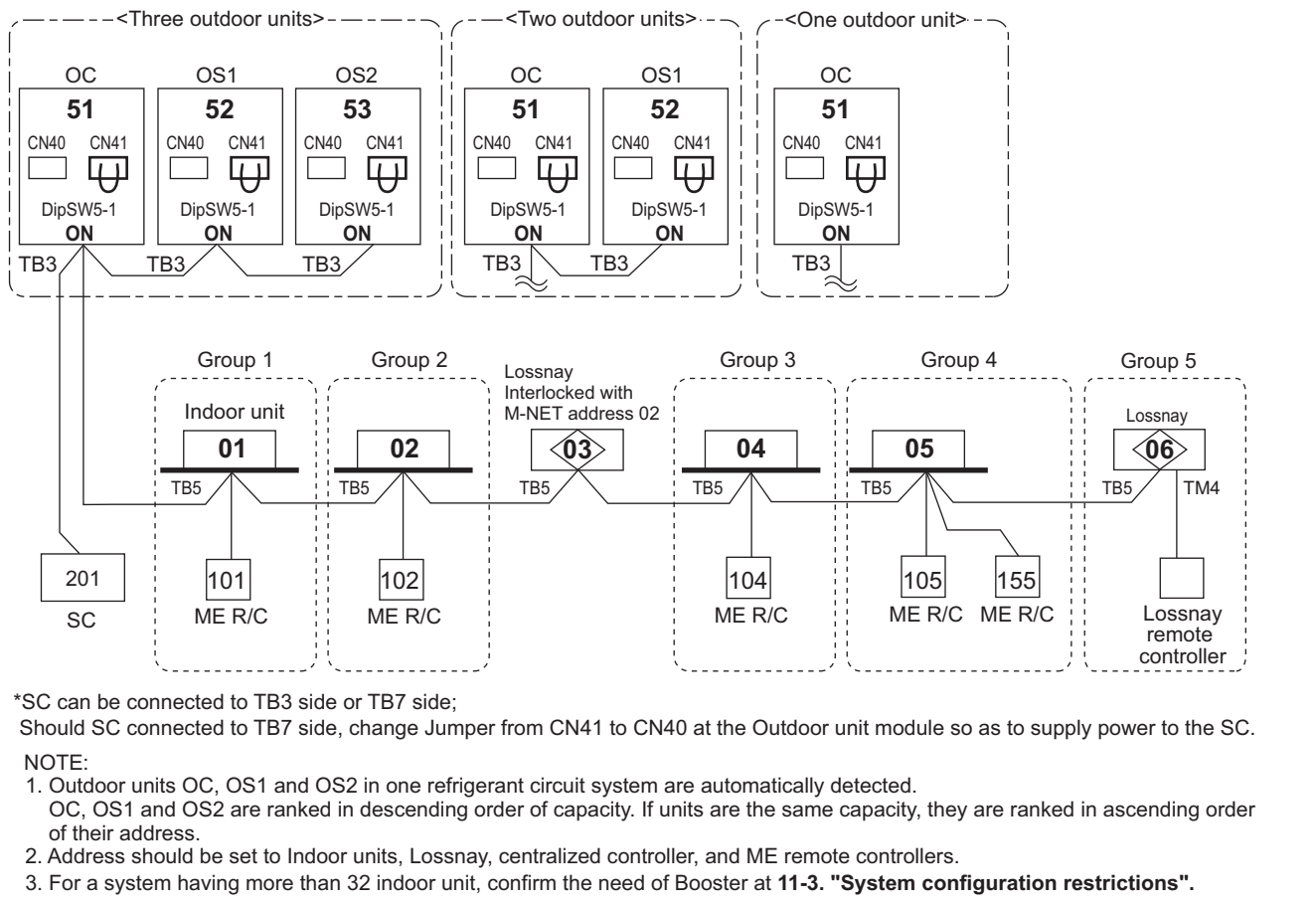

\*SC can be connected to TB3 side or TB7 side;  
Should SC connected to TB7 side, change Jumper from CN41 to CN40 at the Outdoor unit module so as to supply power to the SC.

11-4-3-6. ME remote controller, Multi-refrigerant-system, System Controller at TB 7side, Lossnay, Booster for long M-NET wiring

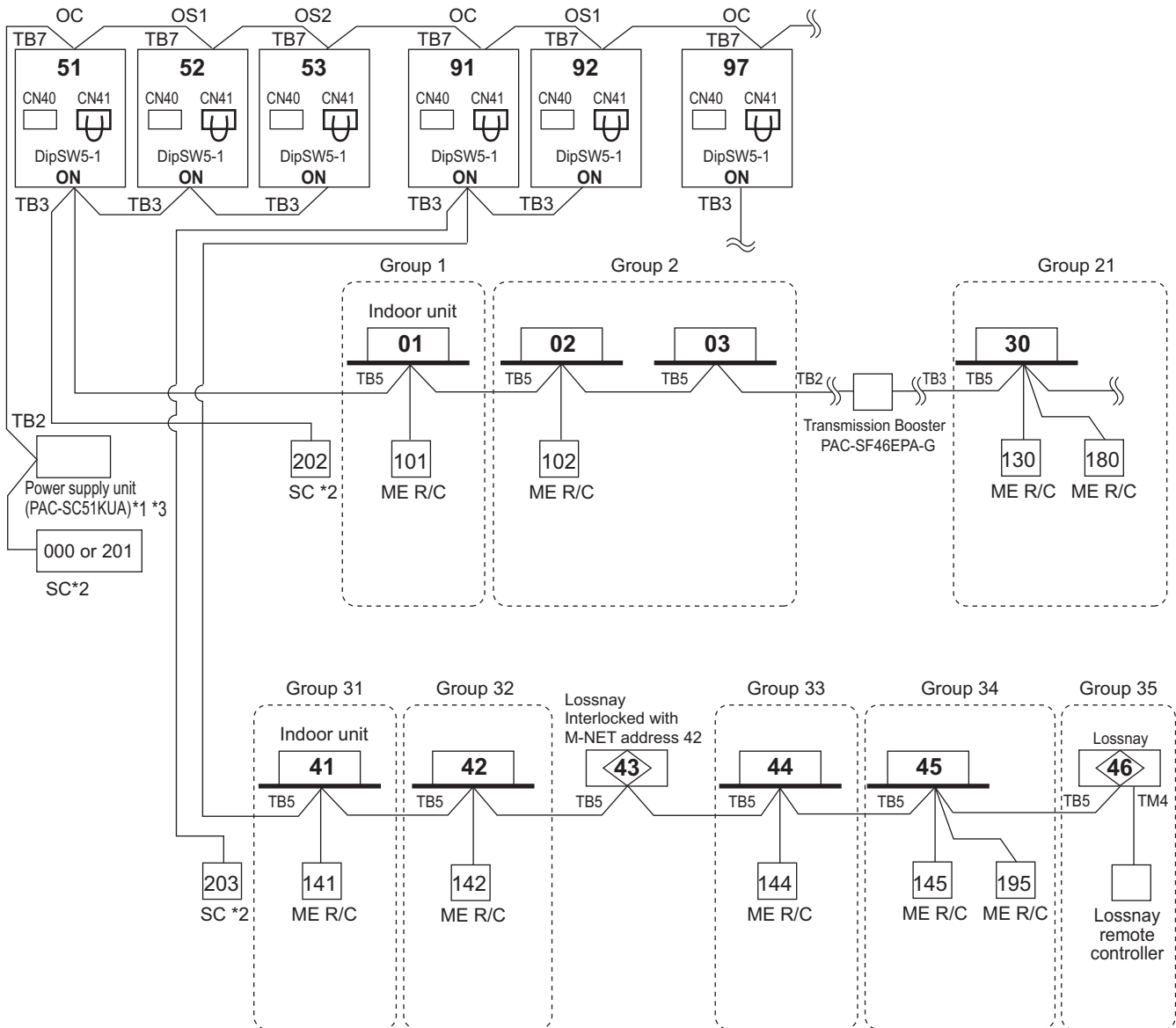

\*1 System controller should connect to TB7 at Outdoor and use power supply unit together in Multi-Refrigerant-System.

For AG-150A, 24V DC should be used with the PAC-SC51KUA.

For AE-200E, AE-50E, and EW-50E the power supply unit PAC-SC51KUA is unused.

\*2 When multiple system controllers are connected in the system, set the controller with more functions than others as a "main" controller and others as "sub".

AE-200E, AE-50E, EW-50E, and BAC-HD150 are for exclusive use as a "main" system controller and cannot be used as a "sub" system controller.

\*3 The power supply unit is not necessary for AE-200E, AE-50E, EW-50E, BAC-HD150, and LM-AP.

NOTE:

- Outdoor units OC, OS1 and OS2 in one refrigerant circuit system are automatically detected. OC, OS1 and OS2 are ranked in descending order of capacity. If units are the same capacity, they are ranked in ascending order of their address.
- M-NET power is supplied by the Outdoor unit at TB3, while Indoor unit and ME remote controller consume the M-NET power for transmission use. The power balance is needed to consider for long M-NET wiring. Details refer to 11-3. "System configuration restrictions".

PUHY-M-YNW-A1, EM-YNW-A1

11-4-3-7. ME remote controller, Multi-refrigerant-system, No Power supply unit

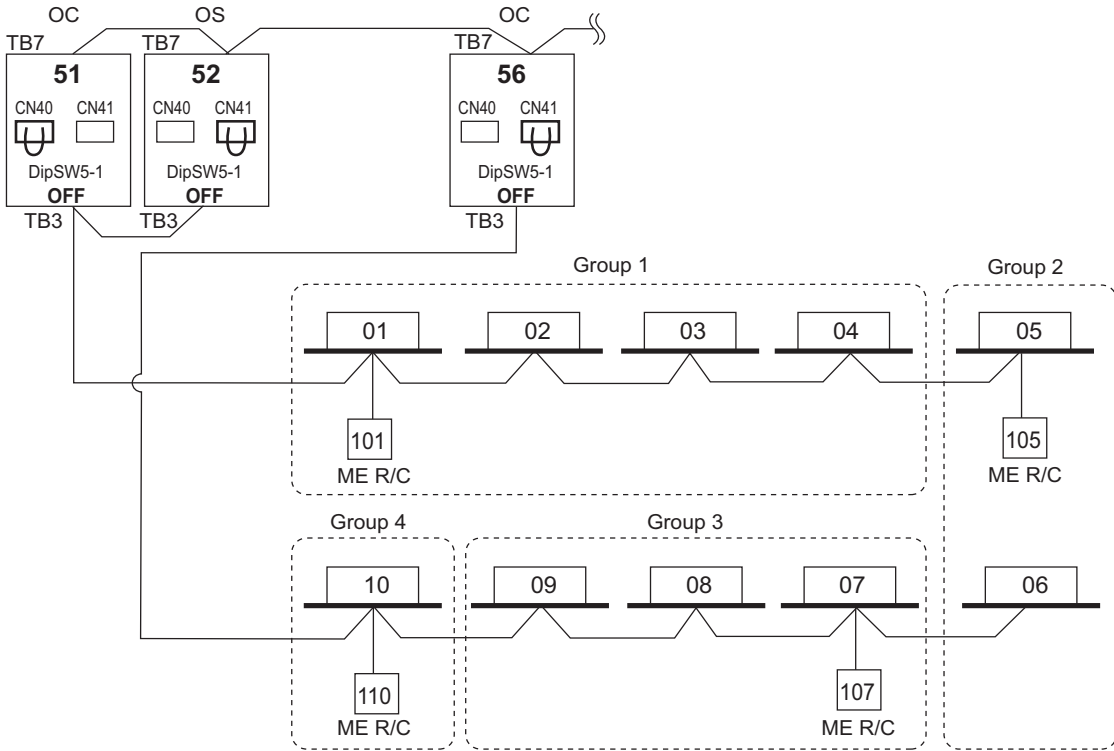

NOTE

- It is necessary to change the connector to CN40 on the outdoor unit control board (only one outdoor unit) when the group is set between other refrigerant systems.
- It is necessary to set on the remote controller by manual when group sets on the different refrigerant system. Please refer to remote controller installation manual.

11-4-3-8. ME remote controller, Multi-refrigerant-system, System Controller at TB7 side, No Power supply unit

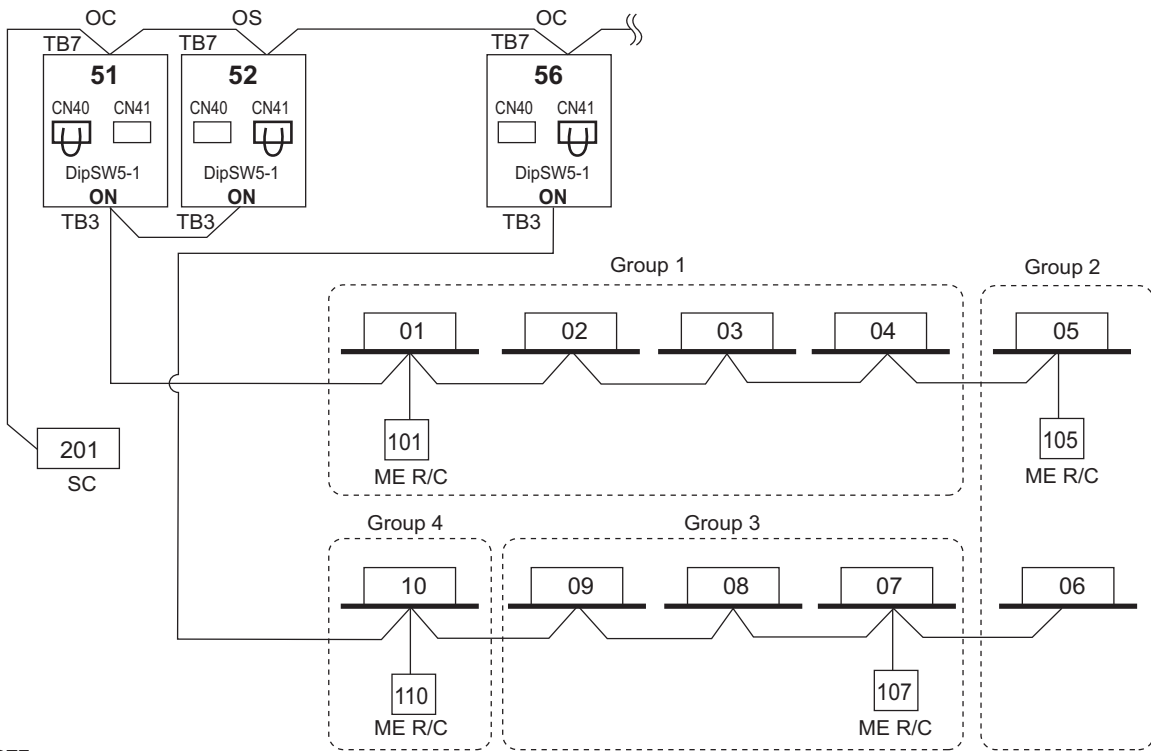

NOTE

- It is necessary to change the connector to CN40 on the outdoor unit control board (only one outdoor unit) when the group is set between other refrigerant systems.
- It is necessary to set on the remote controller by manual when group sets on the different refrigerant system. Please refer to remote controller installation manual.

11-4-3-9. AE-200E + AE-50E/EW-50E  
 AE-200E can control max. 200 indoor units/via AE-50E/EW-50E.

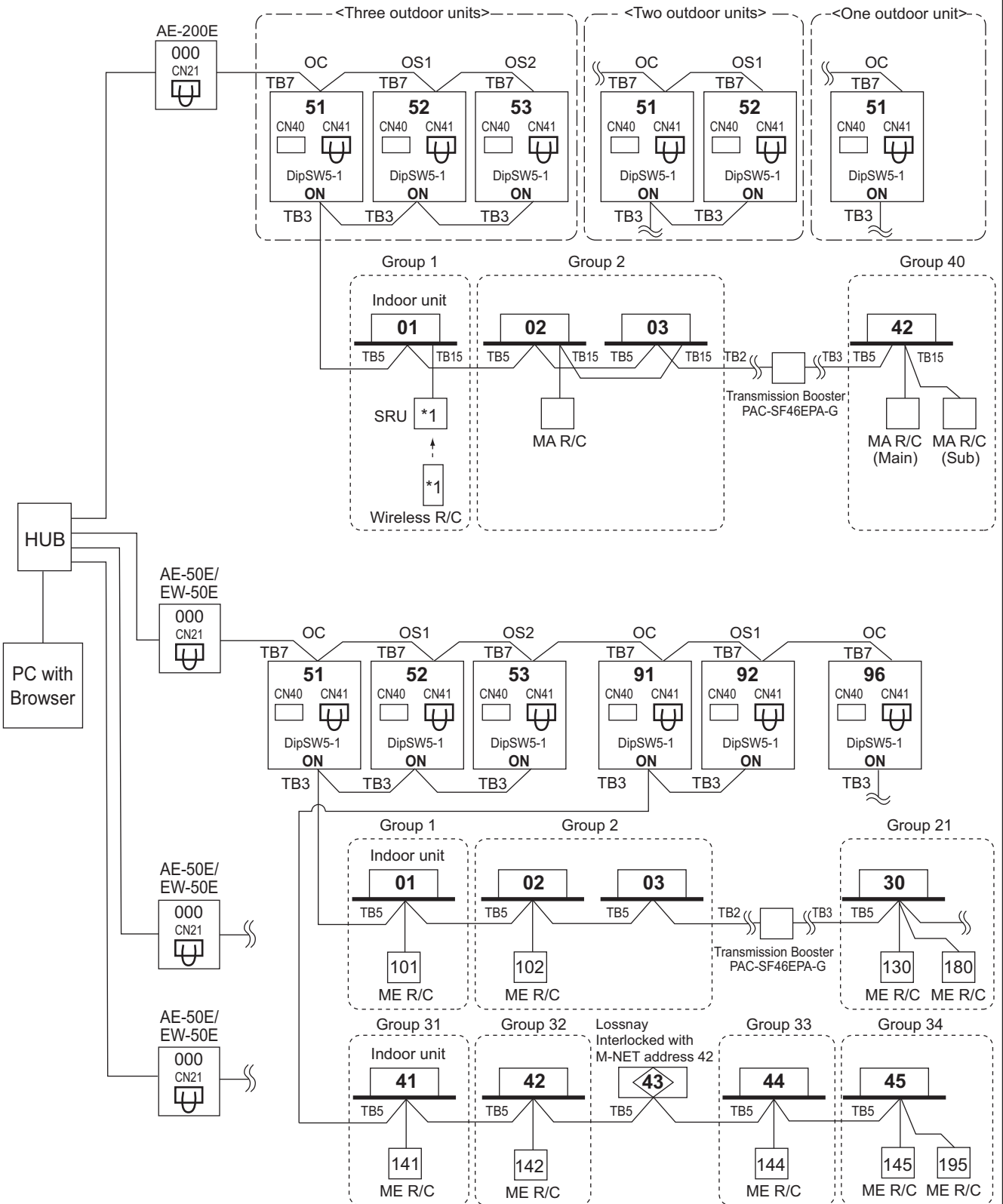

\*1 For Wireless R/C and Signal receiver unit (SRU), channel 1, 2 and 3 are selectable and should be set to same channel.

\*2 When a PAR-CT01MA or PAR-4X MA-Series (X indicates 1, 2...) is connected to a group, no other MA remote controllers can be connected to the same group.

PUHY-M-YNW-A1, EM-YNW-A1

PUHY-M-YNW-A1, EM-YNW-A1

11-4-3-10. LM-AP

LM-AP can transmit for max. 50 indoor units;

If system controller (SC) is used, DipSW1-2 at LM-AP and DipSW5-1 at Outdoor unit should set to "ON".

Change Jumper from CN41 to CN40 to activate power supply to LM-AP itself for those LM-AP connected without system controller (SC).

LM-AP can transmit for max. 50 indoor units in single-refrigerant-system or multi-refrigerant-system.

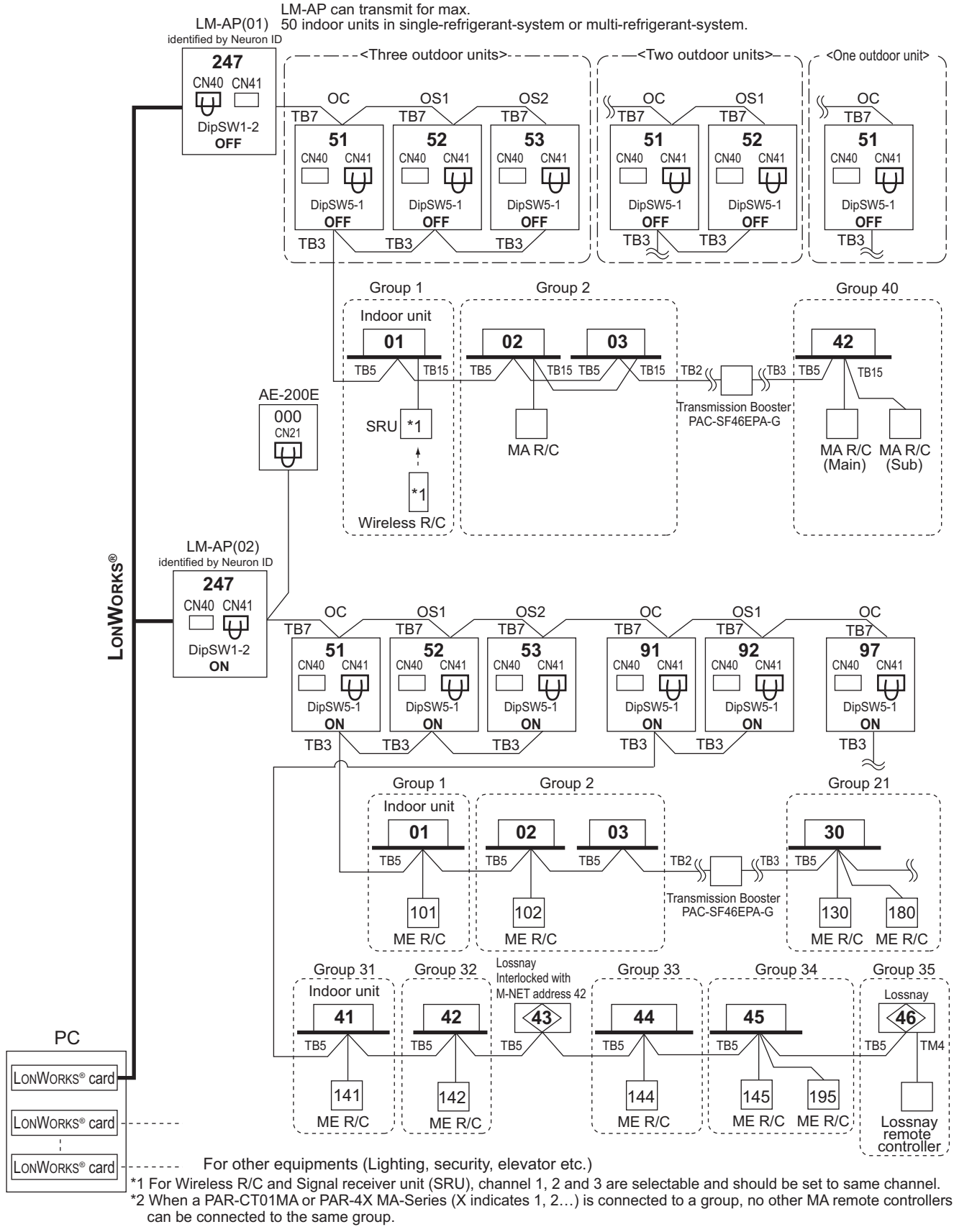

11-4-3-11. BACnet®

**EW-50E (AE-200E) can control up to 50 units/groups (including Lossnay).**

\*To use the BACnet® function on EW-50E (AE-200E), BACnet® license registration is required.

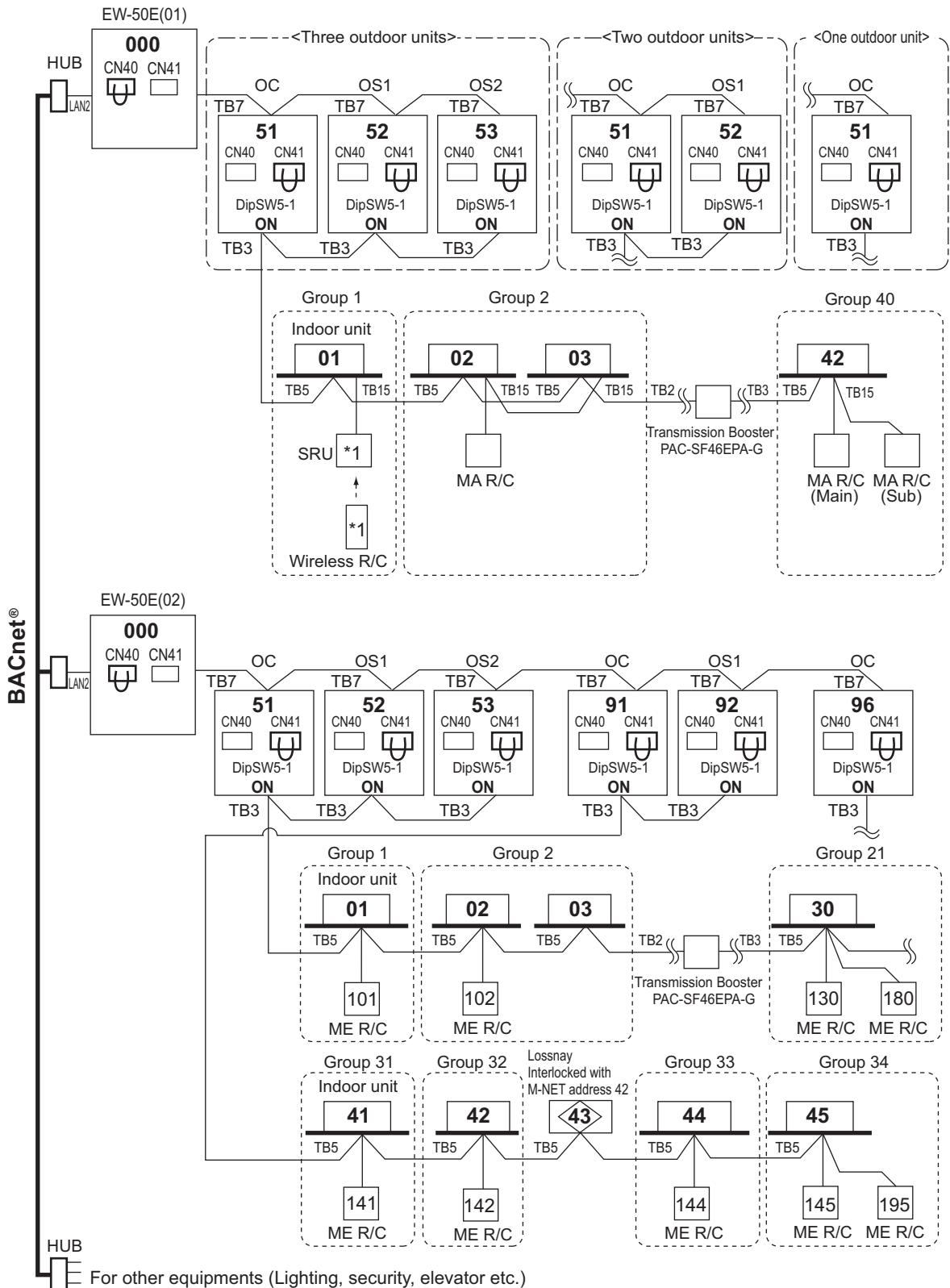

\*1 For Wireless R/C and Signal receiver unit (SRU), channel 1, 2 and 3 are selectable and should be set to same channel.

\*2 When a PAR-CT01MA or PAR-4X MA-Series (X indicates 1, 2...) is connected to a group, no other MA remote controllers can be connected to the same group.

## 12-1. R32 Piping material

Refrigerant pipe for CITY MULTI shall be made of phosphorus deoxidized copper, and has two types.

A. Type-O: Soft copper pipe (annealed copper pipe), can be easily bent with human's hand.

B. Type-1/2H pipe: Hard copper pipe (Straight pipe), being stronger than Type-O pipe of the same radical thickness.

The maximum operation pressure of R32 air conditioner is 4.30 MPa [623psi]. The refrigerant piping should ensure the safety under the maximum operation pressure. MITSUBISHI ELECTRIC recommends pipe size as Table 1, or You shall follow the local industrial standard. Pipes of radical thickness 0.7mm or less shall not be used.

Table 1. Copper pipe size and radial thickness for R32 CITY MULTI.

Size (mm)	Size (inch)	Radial thickness (mm)	Radial thickness (mil)	Pipe type
ø6.35	ø1/4"	0.8	[32]	Type-O
ø9.52	ø3/8"	0.8	[32]	Type-O
ø12.7	ø1/2"	0.8	[32]	Type-O
ø15.88	ø5/8"	1.0	[40]	Type-O
ø19.05	ø3/4"	1.2	[48]	Type-O
ø19.05	ø3/4"	1.0	[40]	Type-1/2H or H
ø22.2	ø7/8"	1.0	[40]	Type-1/2H or H
ø25.4	ø1"	1.0	[40]	Type-1/2H or H
ø28.58	ø1-1/8"	1.0	[40]	Type-1/2H or H
ø31.75	ø1-1/4"	1.1	[44]	Type-1/2H or H
ø34.93	ø1-3/8"	1.2	[48]	Type-1/2H or H
ø41.28	ø1-5/8"	1.4	[56]	Type-1/2H or H

\* For pipe sized ø19.05 (3/4") for R32 air conditioner, choice of pipe type is up to you.

\* The figures in the radial thickness column are based on the Japanese standards and provided only as a reference. Use pipes that meet the local standards.



**Procedures for installing the branched pipes**

Refer to the instructions that came with the branched pipe kit (separately sold) for details.

[1] Branches on the indoor-unit side

**■Joint**

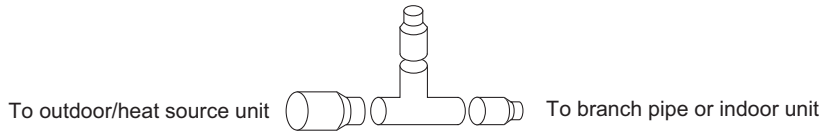

**Horizontal installation**

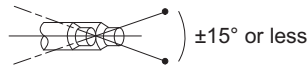

**Vertical installation**

**(The branched pipes must face up.)**  
Indoor-unit side (branched pipe)

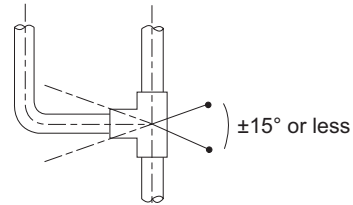

Outdoor/heat source-unit side (main pipe)

- If the size of the refrigerant pipe that is selected by following the instructions under “Piping Design” section does not match the size of the joint, use a reducer to connect them. A reducer is included in the kit.

**■Header**

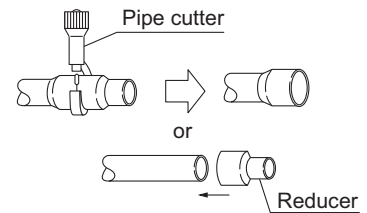
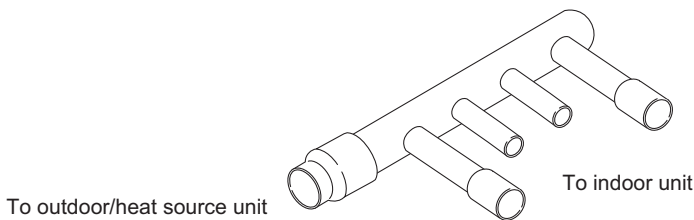

- No restrictions apply to the installation of the header.
- If the size of the refrigerant pipe that is selected by following the instructions under “Piping Design” section does not match the size of the header, cut the pipe to an appropriate size using a pipe cutter, or use a reducer to connect them.
- If the number of header branches exceeds the number of pipes to be connected, cap the unused header branches. Caps are included in the kit.

## 12-2. Piping Design

## Rule for piping size selection

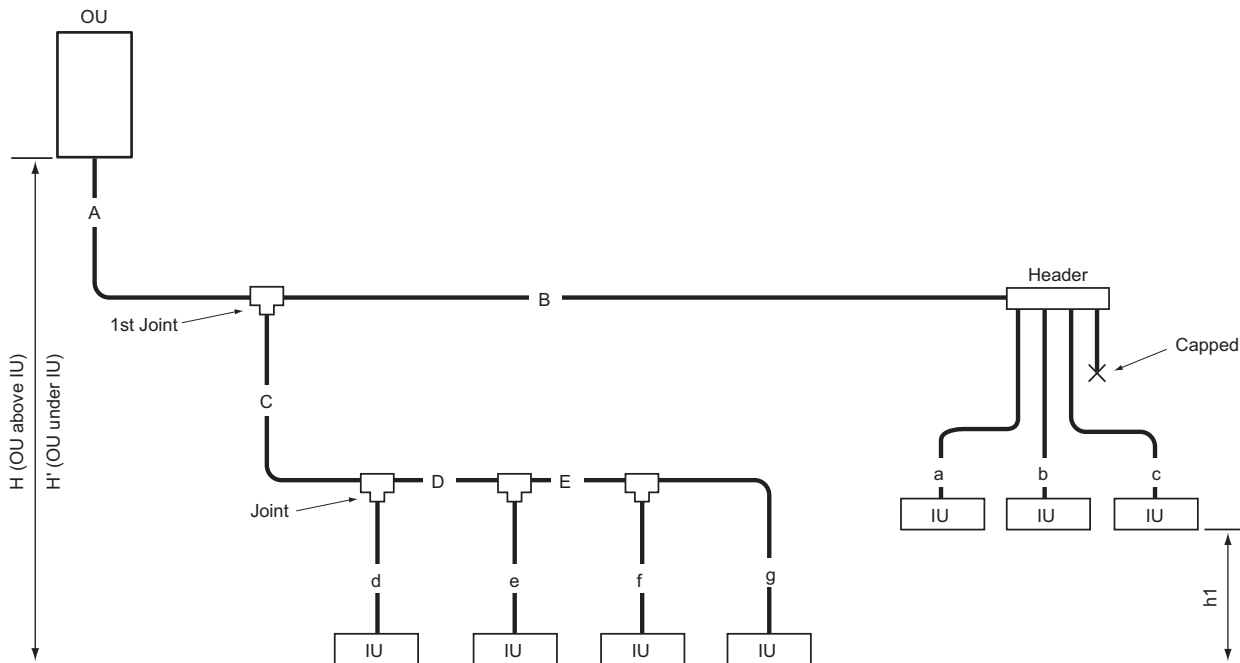

IU: Indoor unit, OU: Outdoor unit

## 1. Selecting joints

Select joints from Table 4-1 [Selection criteria for joints] based on the total capacity of indoor units on the downstream side.

When selecting the first joint for the system to which the outdoor unit listed in Table 4-2 [See the table below for the first joint of the outdoor unit described below.] is connected, select the first joint from Table 4-2.

## 2. Selecting headers

Select headers from Table 5 [Header selection rule] based on the number of indoor units to be connected.

Refer to Table 5, which shows the total capacity limits, for the indoor units to be connected on the downstream side.

When connecting a header directly to the outdoor unit, select the header by referring to the notes in Table 5.

\*The piping cannot be branched on the downstream of the header.

## 3. Selecting refrigerant pipe sizes

## (1) Between outdoor unit and the 1st joint [A]

Select the appropriate size pipes for the selected outdoor unit from Table 1 [Piping "A" size selection rule].

## (2) Between joints [B, C, D, and E]

Select the appropriate size pipes from Table 2 [Piping "B", "C", "D", ... size selection rule] based on the total capacity of indoor units on the downstream side.

## (3) Between joints and indoor units [a, b, c, d, e, f, and g]

Select the appropriate size pipes from Table 3 [Piping "a", "b", "c", "d", ... size selection rule] based on the capacity of indoor units.

## (4) After selecting the pipe sizes in accordance with steps (1) through (3) above, if the size of the pipes on the downstream is larger than that on the upstream, it is not necessary to be bigger than the upstream one.

## (5) If any of the following applies to the selection made in Item 3-(1)-(4) above, reselect the pipe size.

(Not applicable to some models)

(a) If the length of the pipe to any indoor unit from the first joint exceeds 40 m [131 ft.], use one size larger liquid pipe after the joint that is located before the point where the pipe length exceeds 40 m [131 ft.].

(b) Set indoor unit(s) which is vertically closer to the outdoor unit as "base unit(s)".

Only the indoor units that have a height difference of more than 15 m [49 ft.] from base unit will be termed "Target units".

Use one size larger liquid pipe from the target units to the joint prior to which 15 m [49 ft.] height difference has exceeded.

(Not applicable to the liquid pipes whose sizes were increased under item (5)-(a)).

## (6) Calculate the amount of refrigerant to be added based on the pipe sizes selected in Items 1 through 3-(5) above, and make sure that the total amount of the initial charge and the additional charge combined will not exceed the maximum allowable refrigerant charge amount.

If this amount exceeds the maximum allowable amount, redesign the system (i.e., piping length) so that the total refrigerant charge will not exceed the maximum allowable amount.

12-2-1. PUHY-(E)M200-300YNW-A1 Piping

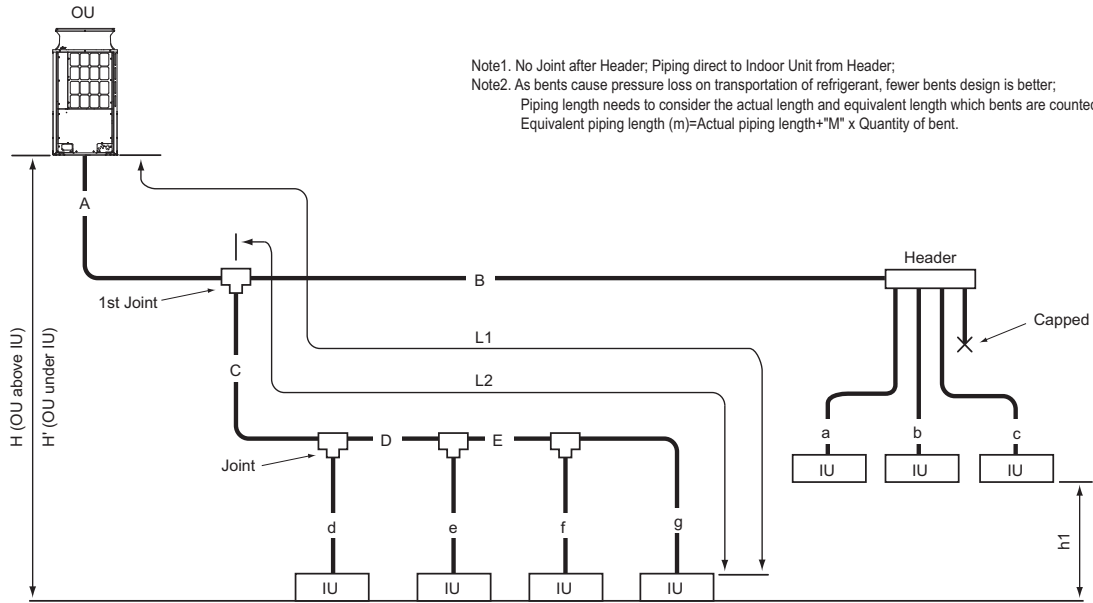

Note1. No Joint after Header; Piping direct to Indoor Unit from Header;  
 Note2. As bents cause pressure loss on transportation of refrigerant, fewer bents design is better;  
 Piping length needs to consider the actual length and equivalent length which bents are counted.  
 Equivalent piping length (m)=Actual piping length+“M” x Quantity of bent.

Fig. 12-2-1A Piping scheme

IU : Indoor unit , OU : Outdoor unit

Piping length	Item	Piping in the figure	(m [ft.])		Bent equivalent length "M"	
			Max. length	Max. equivalent length	Outdoor unit model	M (m/bent [ft./bent])
Total piping length		A+B+C+D+E+a+b+c+d+e+f+g	1000 [3280']	-	PUHY-(E)M200YNW-A1	0.42 [1.38]
Farthest IU from OU (L1)		A+C+D+E+g / A+B+c	165 [541']	190 [623']	PUHY-(E)M250YNW-A1	0.42 [1.38]
Farthest IU from first Joint (L2)		C+D+E+g / B+c	40 [131']	40 [131']	PUHY-(E)M300YNW-A1	0.42 [1.38]
Height between OU and IU (OU above IU)		H	50 [164'] *2	-		
Height between OU and IU (OU under IU)		H'	40 [131'] *3	-		
Height between IU and IU		h1	15 [49'] *1	-		

OU: Outdoor Unit, IU: Indoor Unit

- \*1 30 m is available. If the height difference between indoor units exceeds 15 m (but does not exceed 30 m), use one-size larger pipes for indoor unit liquid pipes. In the figure above, if "h1" exceeds 15 m, increase the size of the liquid piping labeled d, e, f, and g by one size.
- \*2 If height differences exist both between the OU and the 1st Joint as well as between the 1st Joint and the IU, the total height differences between the 1st Joint and each of the indoor units must fall within the height difference range shown in Fig. 1.
- \*3 If height differences exist both between the OU and the 1st Joint as well as between the 1st Joint and the IU, the total height differences between the 1st Joint and each of the indoor units must fall within the height difference range shown in Fig. 2.

Fig. 1 When the outdoor unit is above the indoor unit

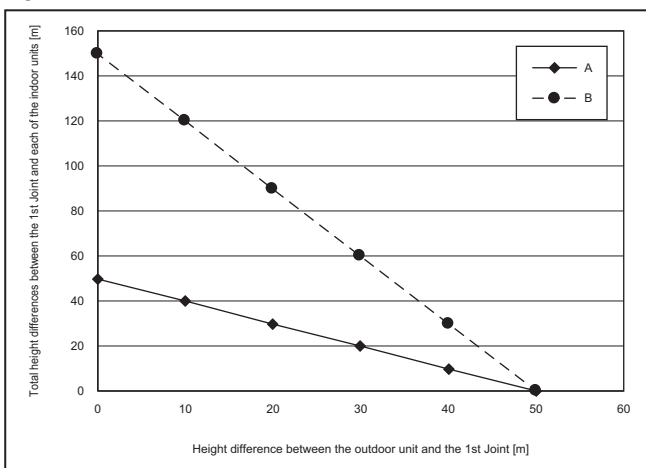

Height difference between the outdoor unit and the 1st Joint	m	50	40	30	20	10	0
Total height differences between the 1st Joint and each of the indoor units (When the pipe length between the OU and the 1st Joint is 110 m: A)	m	0	10	20	30	40	50
Total height differences between the 1st Joint and each of the indoor units (When the pipe length between the OU and the 1st Joint is 60 m: B)	m	0	30	60	90	120	150

Fig. 2 When the outdoor unit is below the indoor unit

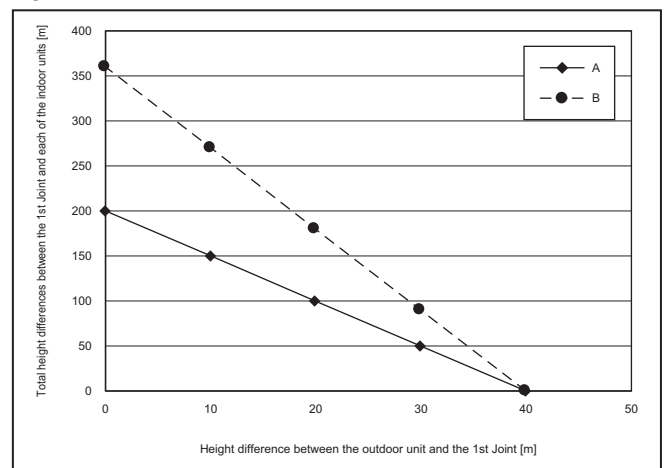

Height difference between the outdoor unit and the 1st Joint	m	40	30	20	10	0
Total height differences between the 1st Joint and each of the indoor units (When the pipe length between the OU and the 1st Joint is 110 m: A)	m	0	50	100	150	200
Total height differences between the 1st Joint and each of the indoor units (When the pipe length between the OU and the 1st Joint is 60 m: B)	m	0	90	180	270	360

**Table 1 Piping "A" size selection rule (mm [in.])**

Outdoor unit	Pipe(Liquid)	Pipe(Gas)
PUHY-(E)M200YNW-A1	ø9.52 [3/8"]	ø22.20 [7/8"]
PUHY-(E)M250YNW-A1	ø9.52 [3/8"]	ø22.20 [7/8"]
PUHY-(E)M300YNW-A1	ø9.52 [3/8"]	ø22.20 [7/8"]

**Table 2 Piping "B", "C", "D", "E" size selection rule (mm [in.])**

Total down-stream Indoor capacity	Pipe(Liquid)	Pipe(Gas)
~ M140	ø9.52 [3/8"]	ø15.88 [5/8"]
M141 ~ M200	ø9.52 [3/8"]	ø19.05 [3/4"]
M201 ~ M300	ø9.52 [3/8"]	ø22.20 [7/8"]
M301 ~ M390	ø12.70 [1/2"]	ø28.58 [1-1/8"]

**Table 3 Piping "a", "b", "c", "d", "e", "f", "g" size selection rule (mm [in.])**

Indoor Unit size	Pipe(Liquid)	Pipe(Gas)
M10, M15, M20, M25, M32, M40, M50	ø6.35 [1/4"]	ø12.70 [1/2"]
M63, M71, M80, M100, M125, M140	ø9.52 [3/8"]	ø15.88 [5/8"]

**Table 4-1 Selection criteria for joints**

Total down-stream Indoor capacity	Joint
~ M200	CMY-Y102SS-G2
M201 ~ M400	CMY-Y102LS-G2

\*Concerning detailed usage of Joint parts, refer to its Installation Manual.

**Table 4-2**

See the table below for the first joint of the outdoor unit described below.

Outdoor unit model	Joint model
(E)M200 to (E)M300	CMY-Y102LS-G2

**Table 5 Header selection rule**

	4-branch Header	8-branch Header	10-branch Header
	CMY-Y104-G	CMY-Y108-G	CMY-Y1010-G
Total down-stream Indoor capacity	<=M200	<=M400	<=M650

\* CMY-Y104-G can directly connect PUHY-(E)M200YNW-A1, but can NOT directly connect PUHY-(E)M250YNW-A1 or above;

\* CMY-Y108-G can directly connect PUHY-(E)M200-300YNW-A1 or above;

\* CMY-Y1010-G can directly connect PUHY-(E)M200-300YNW-A1;

\* Concerning detailed usage of Header parts, refer to its Installation Manual.

Note3. Indoor capacity is described as its model size;  
For example, PEFY-M32VMA-E2, its capacity is M32;

Note4. Total down-stream Indoor capacity is the summary of the model size of Indoors downstream.  
For example, PEFY-M25VMA-E2+PEFY-M32VMA-E2: Total Indoor capacity=M25+M32=M57

Note5. Piping sized determined by the Total down-stream indoor capacity is NOT necessary to be bigger than the up-stream one.  
i.e. A>=B; A>=C>=D

PUHY-M-YNW-A1, EM-YNW-A1

### 12-3. Refrigerant charging calculation

At the time of shipping, the outdoor unit is charged with the refrigerant. As this charge does not include the amount needed for extended piping, additional charging for each refrigerant line will be required on site. In order that future servicing may be properly provided, always keep a record of the size and length of each refrigerant line and the amount of additional charge by writing it in the space provided on the outdoor unit.

#### (1) Calculation of additional refrigerant charge

- The amount of refrigerant to be added depends on the size and the total length of the liquid piping.
- Calculate the amount of refrigerant to be charged according to the formula below.
- Round up the calculation result to the nearest 0.1 kg (0.1 oz).

<Additional Charge>

Units "m" and "kg"

<Formula>

- When the piping length from the outdoor unit to the farthest indoor unit is 30.5 m (100 ft) or shorter

$$\text{Amount of additional charge (kg)} = \left[ \begin{array}{|c|} \hline \text{\textcircled{0}9.52 total length} \\ \hline \times 0.06 \text{ (kg/m)} \\ \hline \end{array} \right] + \left[ \begin{array}{|c|} \hline \text{\textcircled{0}6.35 total length} \\ \hline \times 0.024 \text{ (kg/m)} \\ \hline \end{array} \right]$$

Outdoor unit model	Amount (kg)
(E)M200	0
(E)M250	0
(E)M300	0

Total capacity of connected indoor units	Amount (kg)
80 or below	2.0
81 to 160	2.5
161 to 330	3.0
331 to 390	3.5

\* Amount of refrigerant to be charged for single-module units

\* Certain types of indoor units will require additional refrigerant charge. See the separate document titled "ADDITIONAL REFRIGERANT," which is available for download at <http://www.mitsubishielectric.com/ldg/ibim/>.

- When the piping length from the outdoor unit to the farthest indoor unit is longer than 30.5 m (100 ft)

$$\text{Amount of additional charge (kg)} = \left[ \begin{array}{|c|} \hline \text{\textcircled{0}9.52 total length} \\ \hline \times 0.050 \text{ (kg/m)} \\ \hline \end{array} \right] + \left[ \begin{array}{|c|} \hline \text{\textcircled{0}6.35 total length} \\ \hline \times 0.019 \text{ (kg/m)} \\ \hline \end{array} \right]$$

Outdoor unit model	Amount (kg)
(E)M200	0
(E)M250	0
(E)M300	0

Total capacity of connected indoor units	Amount (kg)
80 or below	2.0
81 to 160	2.5
161 to 330	3.0
331 to 390	3.5

\* Amount of refrigerant to be charged for single-module units

\* Certain types of indoor units will require additional refrigerant charge. See the separate document titled "ADDITIONAL REFRIGERANT," which is available for download at <http://www.mitsubishielectric.com/ldg/ibim/>.

Example: PUHY-(E)M300YNW-A1

PUHY-M-YNW-A1, EM-YNW-A1

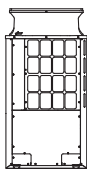

Indoor	1: M100	A: ø9.52	40 m	a: ø9.52	10 m
	2: M100	B: ø9.52	10 m	b: ø9.52	5 m
	3: M50	C: ø9.52	15 m	c: ø6.35	10 m
	4: M40	D: ø9.52	10 m	d: ø6.35	10 m
	5: M71			e: ø9.52	10 m

The total length of liquid pipe of each size is as follows:  
 ø9.52: A + B + C + D + a + b + e = 40 + 10 + 15 + 10 + 10 + 5 + 10 = 100 m  
 ø6.35: c + d = 10 + 10 = 20 m

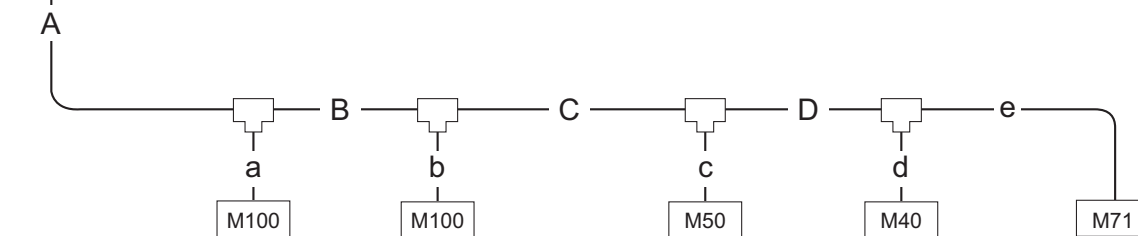

Additional refrigerant charge (kg)	=	Total length of liquid pipe sized ø9.52 x 0.050 (kg/m)	+	Total length of liquid pipe sized ø6.35 x 0.019 (kg/m)	+ 0 + 3.5
		100 (m) x 0.050 (kg/m)		20 (m) x 0.019 (kg/m)	
	=	100 x 0.050	+	20 x 0.019	+ 0 + 3.5
	=	8.9 (8.88) kg			

■ Amount of factory charged refrigerant

Outdoor unit model	Charged amount
(E)M200 (E)M250 (E)M300	6.5kg

■ Maximum refrigerant charge

There is a limit to the amount of refrigerant that can be charged into a unit. Regardless of the amount yielded by the formula above, observe the maximum refrigerant charge in the table below.

Total index of the outdoor units			(E)M200 YNW-A1	(E)M250 YNW-A1	(E)M300 YNW-A1
Maximum refrigerant charge	Factory charged	kg	6.5	6.5	6.5
	Charged on site	kg	18.0	18.5	19.5
	Total for system	kg	24.5	25.0	26.0

**13-1. Requirement on installation site**

1. No direct thermal radiation to the unit.
2. No possibility of annoying the neighbors by the sound of the unit.

**Valves and refrigerant flow on the outdoor unit may generate noise.**

3. Avoid the sites where strong winds blow.
4. With strength to bear the weight of the unit.
5. Drain flow from the unit is cared at heating mode.
6. Enough space for installation and service as shown at 13-2.
7. Avoid the sites where acidic solutions or chemical sprays (sulfuric compounds) are used frequently.
8. The unit should be secure from combustible gas, oil, steam, chemical gas like acidic solution, sulfur gas and so on.

PUHY-M-YNW-A1, EM-YNW-A1

### 13-2. Spacing

#### In case of single installation

(1) When all walls are within their height limits\*.

[mm (in)]

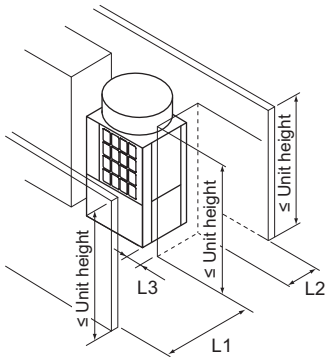

\* Height limit

Front/Right/Left/Rear	Same height or lower than the overall height of the unit
-----------------------	--

	Required minimum distance [mm (in)]		
	L1 (Front)	L2 (Rear)	L3 (Right/Left)
When the distance behind the unit (L2) needs to be small	450 (17-3/4)	100 (3-15/16)	50 (2)
When the distance to the right or left (L3) needs to be small	450 (17-3/4)	300 (11-13/16)	15 (5/8)

(2) When one or more walls exceed their height limits\*.

When the wall(s) at the front and/or the right/left exceed(s) their height limits

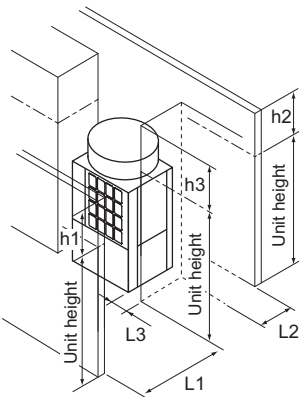

When the wall at the rear exceeds its height limit

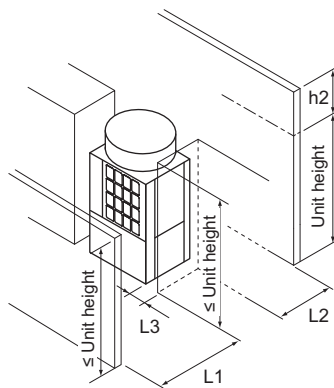

When all walls exceed their height limits

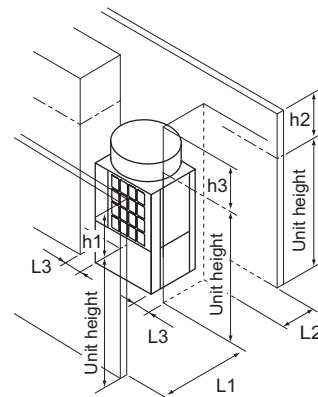

Add the dimension that exceeds the height limit (shown as "h1" through "h3" in the figures) to L1, L2, and L3 as shown in the table below.

	Required minimum distance [mm (in)]		
	L1 (Front)	L2 (Rear)	L3 (Right/Left)
When the distance behind the unit (L2) needs to be small	450 (17-3/4) + h1	100 (3-15/16) + h2	50 (2) + h3
When the distance to the right or left (L3) needs to be small	450 (17-3/4) + h1	300 (11-13/16) + h2	15 (5/8) + h3

(3) When there are overhead obstacles

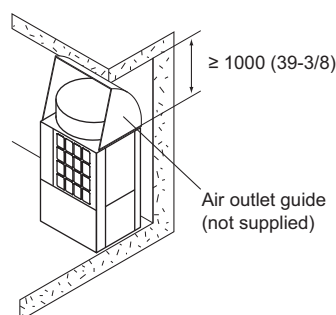
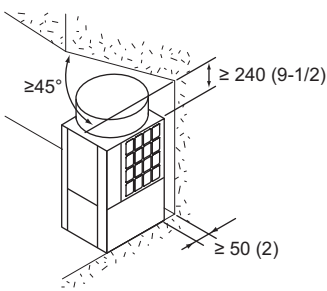



**In case of collective installation and continuous installation**

- When installing multiple units, make sure to take into consideration factors such as providing enough space for people to pass through, ample space between blocks of units, and sufficient space for airflow. (The areas marked with [A] in the figures below must be left open.)
- In the same way as with the single unit installation, add the dimension that exceeds the height limit (shown as "h1" through "h3" in the figures) to L1, L2, and L3 as shown in the tables below.
- If there are walls in the front and rear of the block of units, up to six units can be installed consecutively side by side, and a space of 1000 mm (39-3/8 in) or more must be left between each block of six units.

**(1) Side-by-side installation**

When the distances between the units (L4) need to be small

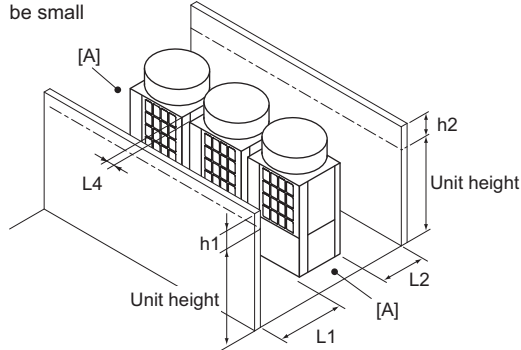

Required minimum distance [mm (in)]		
L1 (Front)	L2 (Rear)	L4 (Between)
450 (17-3/4) + h1	300 (11-13/16) + h2	30 (1-3/16)

When the distance behind the block of units (L2) needs to be small

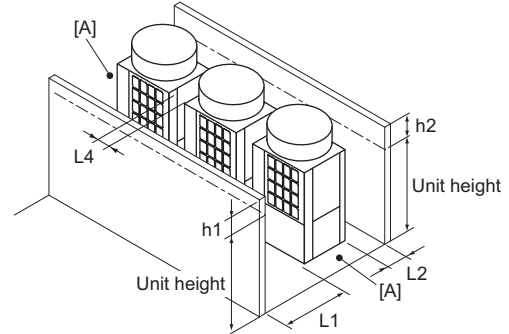

Required minimum distance [mm (in)]		
L1 (Front)	L2 (Rear)	L4 (Between)
450 (17-3/4) + h1	100 (3-15/16) + h2	100 (3-15/16)

**(2) Face-to-face installation**

When there are walls in the front and rear of the block of units

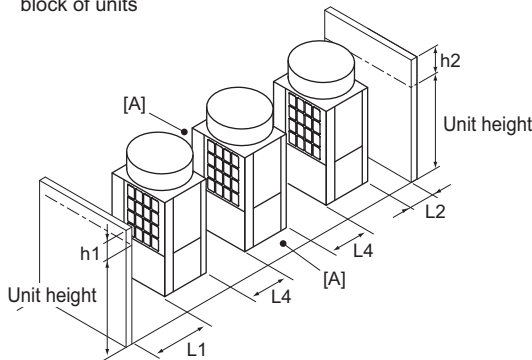

Required minimum distance [mm (in)]		
L1 (Front)	L2 (Rear)	L4 (Between)
450 (17-3/4) + h1	100 (3-15/16) + h2	450 (17-3/4)

When there is a wall on either the right or left side of the block of units

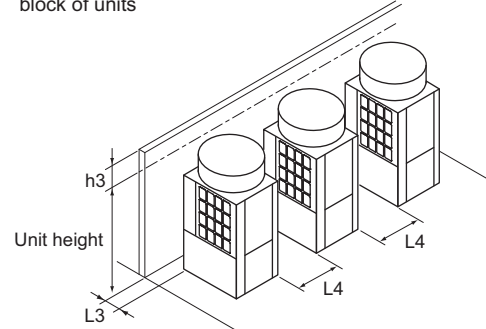

Required minimum distance [mm (in)]	
L3 (Right/Left)	L4 (Between)
15 (5/8) + h3	450 (17-3/4)

**(3) Combination of face-to-face and side-by-side installations**

When there are walls in the front and rear of the block of units

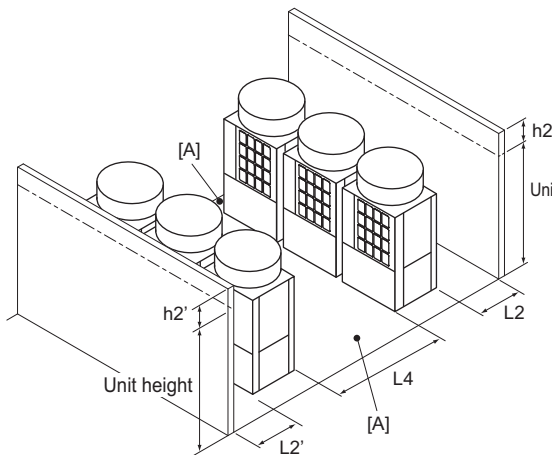

Required minimum distance [mm (in)]		
L2 (Rear)	L2' (Rear)	L4 (Between)
300 (11-13/16) + h2	300 (11-13/16) + h2'	900 (35-7/16)

When there are two walls in an L-shape

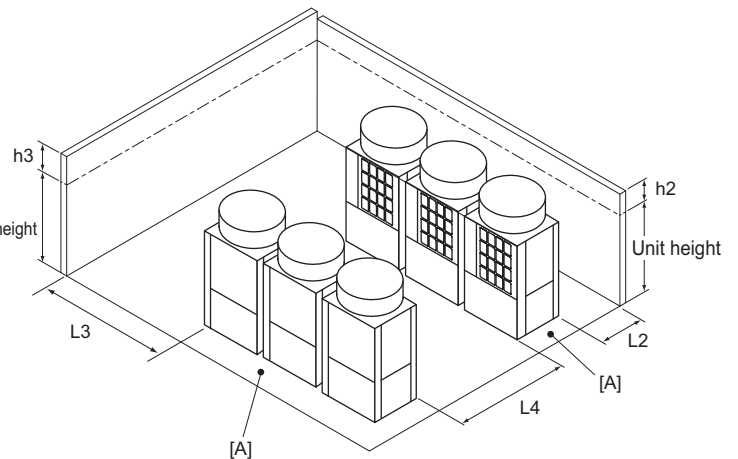

Required minimum distance [mm (in)]		
L2 (Rear)	L3 (Right/Left)	L4 (Between)
300 (11-13/16) + h2	1000 (39-3/8) + h3	900 (35-7/16)

[A]: Leave open in two directions.

### 13-3. Piping direction

#### 13-3-1. Lifting method

- Always use two slings to lift up the unit. Each sling must be at least 8 m (26 ft) long and must be able to support the weight of the unit.
- Put protective pads between slings and the unit where the slings touch the unit at the base to protect the unit from being scratched.
- Put 50 mm (2 in) or thicker protective pads between slings and the unit where the slings touch the unit at the top of the unit to protect the unit from being scratched and to avoid contact with the slings and the fan guard.
- Make sure that the angles between slings at the top are less than 40 degrees

(E)M200, 250, 300

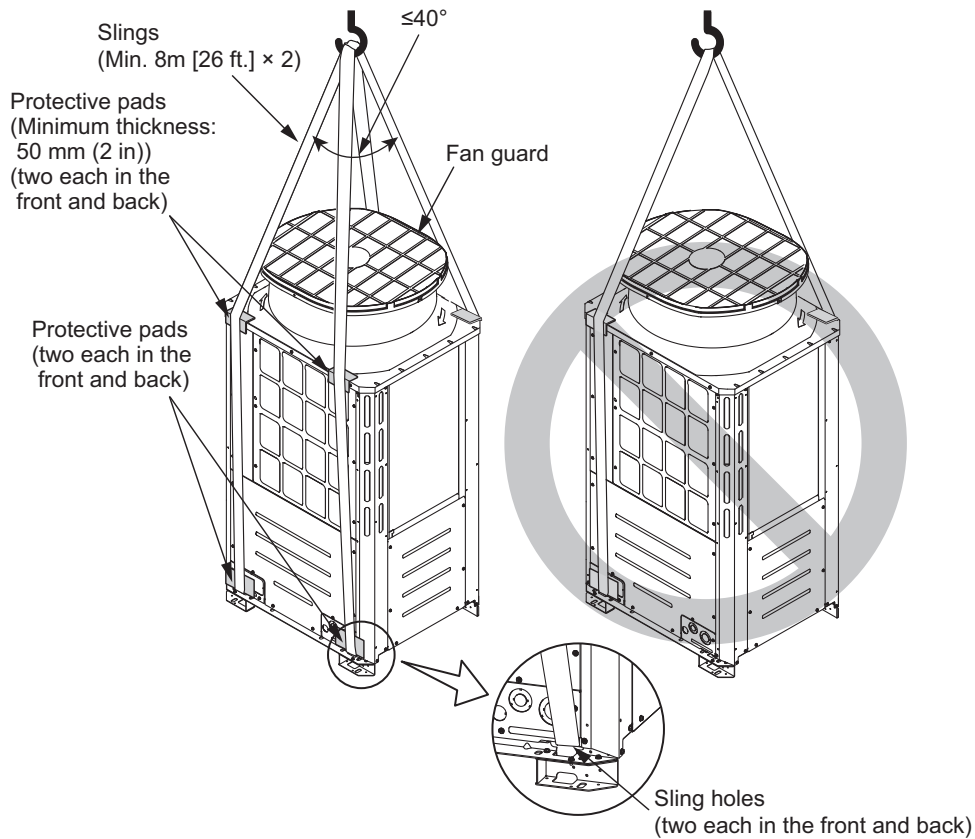

#### CAUTION

##### Exercise caution when transporting products.

- Products weighing more than 20 kg [45 LBS] should not be carried alone.
- Do not carry the product by the PPbands.
- To avoid the risk of injury, do not touch the heat exchanger fins.
- Plastic bags may pose a risk of choking hazard to children. Tear plastic bags into pieces before disposing of them.
- When lifting and transporting outdoor units with ropes, run the ropes through lifting hole at the unit base. Securely fix the unit so that the ropes will not slide off, and always lift the unit at four points to prevent the unit from falling.

13-3-2. Installation

- Secure the unit with anchor bolts as shown in the figure below so that the unit will not topple over with strong wind or during an earthquake.
- Install the unit on a durable base made of such materials as concrete or angle steel.
- Take appropriate anti-vibration measures (e.g., vibration damper pad, vibration isolation base) to keep vibrations and noise from being transmitted from the unit through walls and floors.
- When using a rubber cushion, install it so that the cushion covers the entire width of the unit leg.
- Install the unit in such a way that the corner of the angle bracket at the base of the unit shown in the figure below is securely supported.
- Install the anchor bolt in such a way that the top end of the anchor bolt do not stick out more than 30 mm [1-3/16 in.].
- This unit is not designed to be anchored with post-installation-type anchor bolts, although by adding fixing brackets anchoring with such type of anchor bolts becomes possible.

- (A) M10 anchor bolt (not supplied)
- (B) (Incorrect installation) The corner section is not securely received.
- (C) Fixing bracket for post-installed anchor bolts (not supplied) (To be fixed with three screws)
- (D) Anti-vibration rubber pad (The pad needs to be large enough to cover the entire width of each unit leg.)
- (E) Detachable leg

**WARNING**  
 Properly install the unit on a surface that can withstand the weight of the unit. Unit installed on an unstable surface may fall and cause injury.

**WARNING**  
 Take appropriate safety measures against strong winds and earthquakes to prevent the unit from falling.

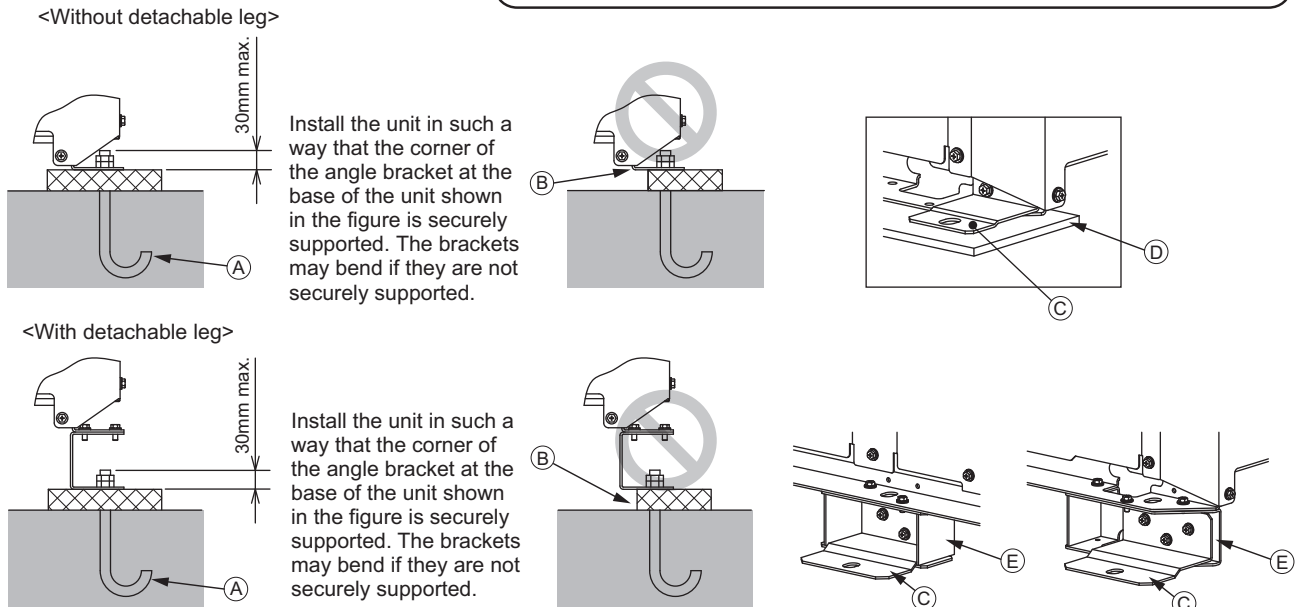

Take into consideration the durability of the base, water drainage route (Drain water is discharged from outdoor units during operation.), piping route, and wiring route when performing foundation work.

13-3-3. Anchor bolt positions

<(E)M200-300>

• Individual installation

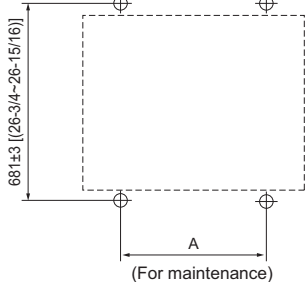

• Collective installation

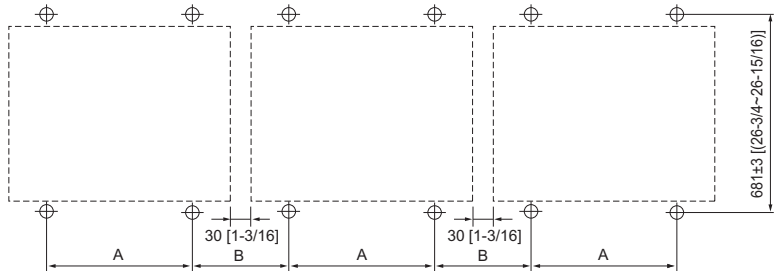

PUHY	(E)M200, 250, 300
A	760±2 [29-15/16(29-7/8~30)]
B	190 [7-1/2]

13-3-4. Installation

When the pipes and/or cables are routed at the bottom of the unit, make sure that the through hole at the base of the unit does not get blocked with the installation base.  
 When the pipes are routed at the bottom of the unit, the base should be at least 100 mm [3-15/16 in.] in height.

(E)M200, 250, 300

(Unit: mm[in.])

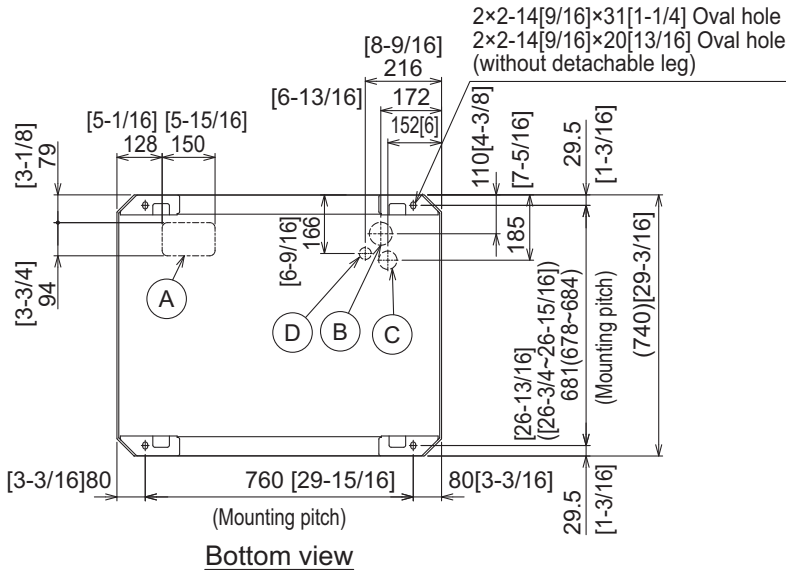

NO.	Usage	Specifications
(A)	For pipes	Bottom through hole 150 × 94 Knockout hole [5-15/16] [3-3/4]
(B)	For wires	Bottom through hole ø65 Knockout hole [2-9/16]
(C)		Bottom through hole ø52 Knockout hole [2-1/16]
(D)	For transmission cables	Bottom through hole ø34 Knockout hole [1-3/8]

Installation base parallel to the unit's front panel

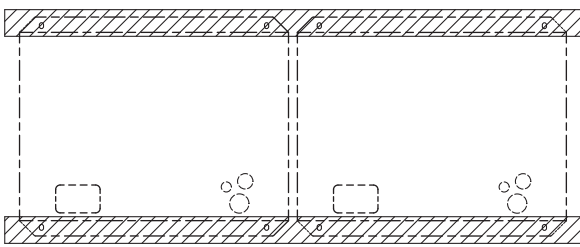

Installation base perpendicular to the unit's front panel

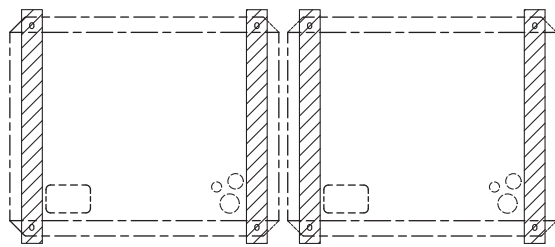

13-3-5. Refrigerant pipe routing

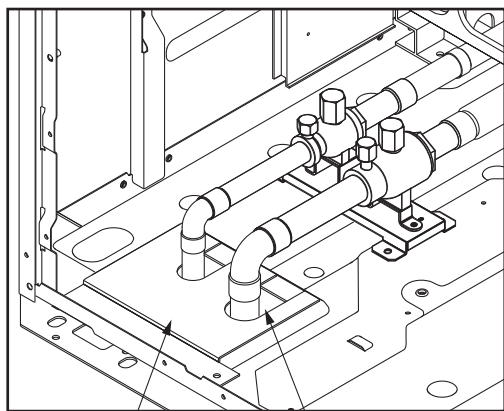

Example of closure materials (field supply)      Fill the gap at the site

The gaps around the edges of through holes for pipes and wires on the unit allow water or mice to enter the unit and damage its parts. Close these gaps with filler plates.

This unit allows two types of pipe routing:

- Bottom piping
- Front piping

**CAUTION**

To prevent small animals, water and snow from entering the unit and damage its parts, close the gap around the edges of through holes for pipes and wires with filler plates.

PUHY-M-YNW-A1, EM-YNW-A1

### 13-4. Countermeasure to wind

Referring to the figure shown below, take appropriate measures which will suit the actual situation of the place for installation. A unit installed alone is vulnerable to strong winds. Select the installation site carefully to minimize the effect of winds. To install a unit in a place where the wind always blows from the same direction, install the unit so that the outlet faces away from the direction of the wind.

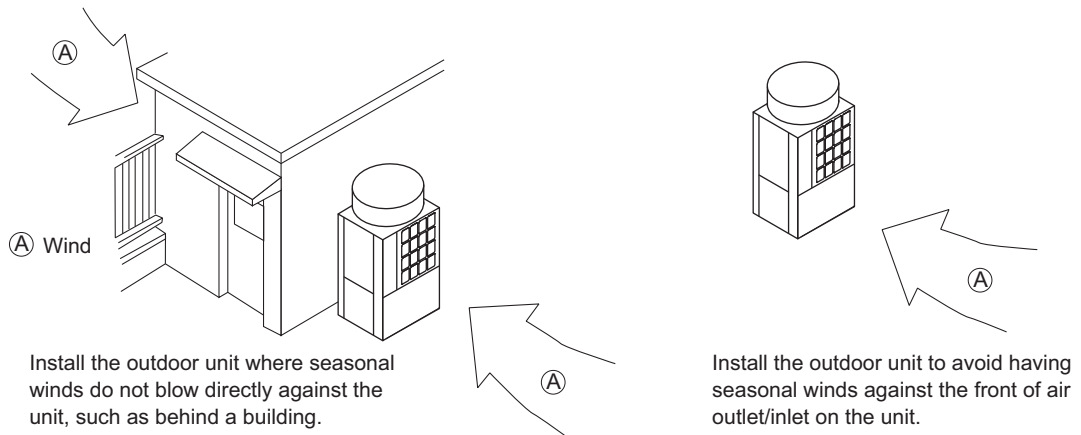

### 13-5. Precautions for installing a panel heater

If there is a risk that the drain water will freeze inside the outdoor unit, the installation of a panel heater is recommended. When installing a panel heater, provide sufficient space for maintenance accordingly. For details, refer to the installation manual for the panel heater.

### 13-6. Caution on selecting outdoor units

Consult your dealer when the following issues on Y-Series are the key concern.

- Warm air may flow out from the indoor unit during heating Thermo-OFF.
- Refrigerant flow sound may occur in the rooms with low background noise such as hotel rooms, hospital rooms, bedrooms, or conference rooms.

To avoid the above issues on Y-Series, changing board settings on the indoor and outdoor units is required. Ask AC&R Works for details.





**for a greener tomorrow**

Eco Changes is the Mitsubishi Electric Group's environmental statement, and expresses the Group's stance on environmental management. Through a wide range of businesses, we are helping contribute to the realization of a sustainable society.

**⚠ Warning**

- Do not use refrigerant other than the type indicated in the manuals provided with the unit and on the nameplate.
  - Doing so may cause the unit or pipes to burst, or result in explosion or fire during use, repair, or at the time of disposal of the unit.
  - It may also be in violation of applicable laws.
  - MITSUBISHI ELECTRIC CORPORATION cannot be held responsible for malfunctions or accidents resulting from the use of the wrong type of refrigerant.
- Our air conditioning equipment and heat pumps contain a fluorinated greenhouse gas, R32.

**MITSUBISHI ELECTRIC CORPORATION**

[www.MitsubishiElectric.com](http://www.MitsubishiElectric.com)